

Investors Presentation

March 2026

Leading the Future

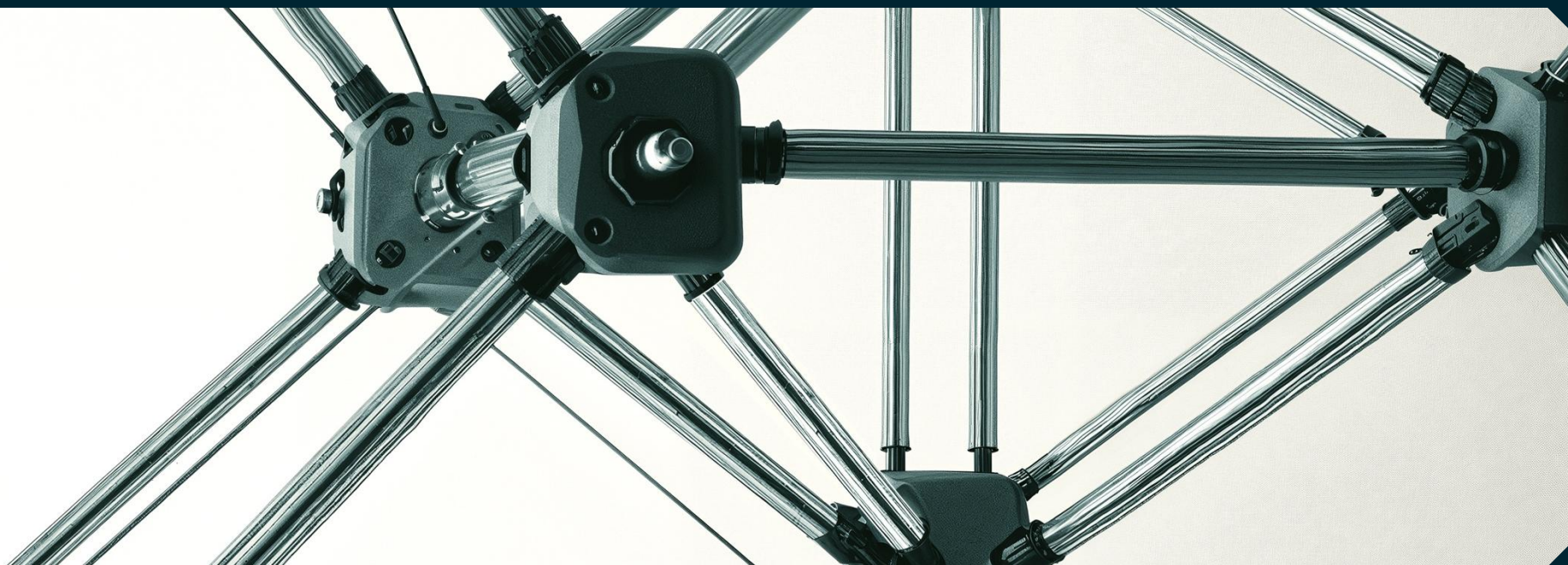

01

OVERVIEW

02

STRATEGIC
PLAN LEADING
THE FUTURE

03

FINANCIAL
PROJECTIONS

04

ANNEX 2025
RESULTS

This presentation has been produced by Indra for the sole purpose expressed therein. Therefore, neither this presentation nor any of the information contained herein constitutes an offer sale or exchange of securities, invitation to purchase or sale shares of the Company or any advice or recommendation with respect to such securities.

Its content is purely for information purposes and the statement it contains may reflect certain forward-looking statements, expectations and forecasts about the Company at the time of its elaboration. These expectations and forecasts are not in themselves guarantees of future performance as they are subject to risks, uncertainties and other important factors beyond the control of the Company that could result in final

results materially differing from those contained in these statements. The Company does not assume any obligation or liability in connection with the accuracy of the mentioned estimations and is not obliged to update or revise them.

This document contains information that has not been audited. In this sense, this information is subject to, and must be read in conjunction with, all other publicly available information.

This disclaimer should be taken into consideration by all the individuals or entities to whom this document is targeted and by those who consider that they have to make decisions or issue opinions related to securities issued by Indra.



Overview

Indra's Vision and Main 2025 Figures

Become the Spanish multinational of reference in Defence & Aerospace and Advanced Digital Technologies

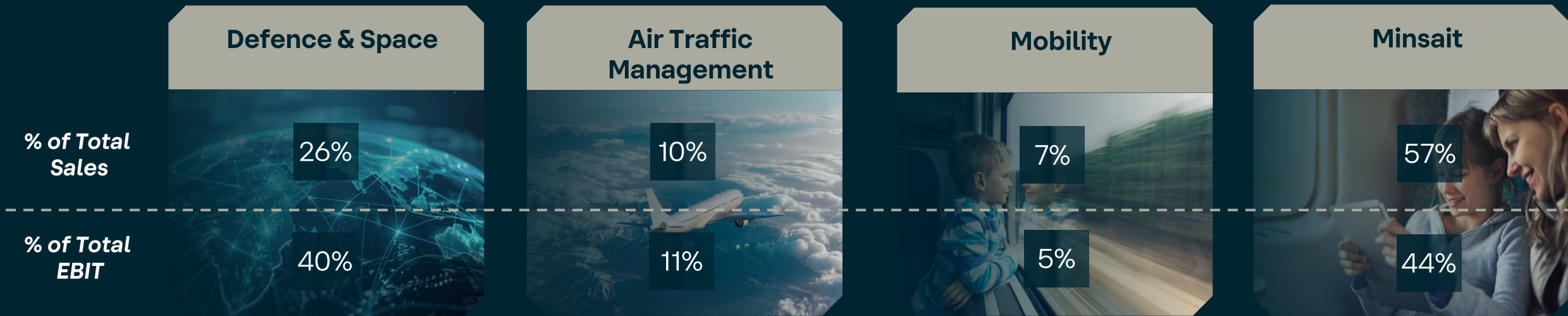

Revenues 2025
€5.5Bn

EBITDA 2025
€636m
EBITDA margin
11.7%

EBIT 2025
€517m
EBIT margin
9.5%

>140
Countries

~62,000
Employees

€472m
In R&D

Breakdown by Geography and Division

FY25 Revenues breakdown by Geography

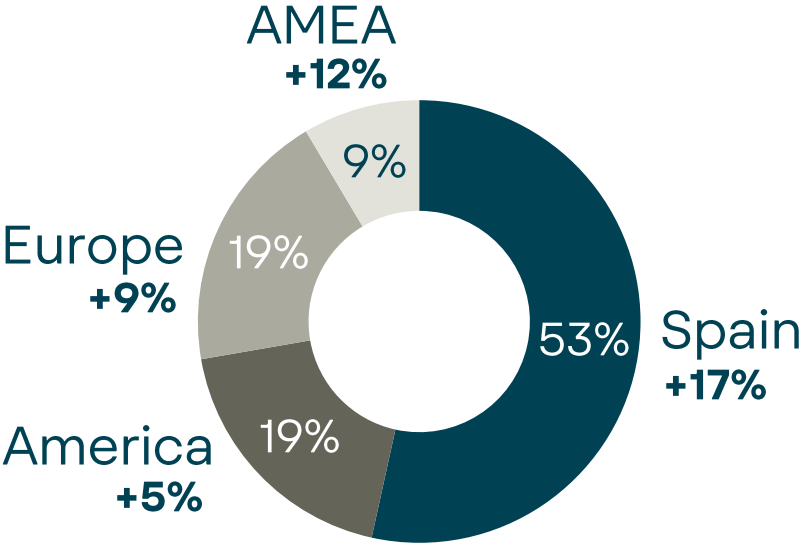

International Business covering 47%

FY25 EBITDA breakdown by Division

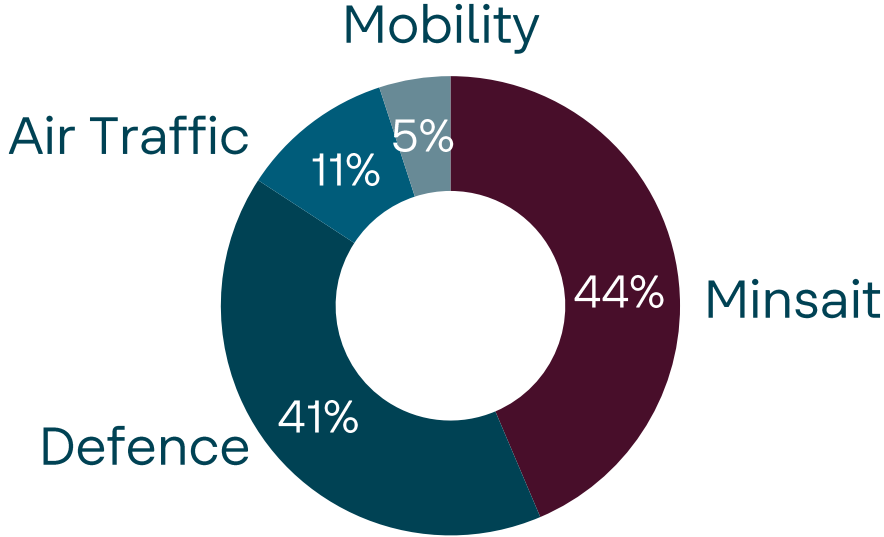

Defence, ATM and Mobility EBITDA account for 56% of total

Main Figures by Division

Defence	2025	2024	Variation (%)
	(€m)	(€m)	Reported / Local currency
Backlog	11,336	2,972	281.5 / 281.6
Net Order Intake	8,160	1,053	675.0 / 675.2
Revenues	1,407	1,031	36.4 / 36.5
EBITDA	258	207	25.0
EBITDA Margin %	18.4%	20.0%	(1.6) pp
Operating Margin	240	191	25.6
Operating Margin %	17.1%	18.5%	(1.4) pp
EBIT	232	186	24.5
EBIT margin %	16.5%	18.0%	(1.5) pp
Book-to-bill	5.80	1.02	468.2
Backlog / Revs LTM	8.06	2.88	179.7

Minsait	2025	2024	Variation (%)
	(€m)	(€m)	Reported / Local currency
Backlog	2,681	2,460	9.0 / 11.5
Net Order Intake	3,424	3,306	3.6 / 5.6
Revenues	3,129	2,982	4.9 / 7.0
EBITDA	277	241	15.2
EBITDA Margin %	8.9%	8.1%	0.8 pp
Operating Margin	270	240	12.4
Operating Margin %	8.6%	8.1%	0.5 pp
EBIT	208	176	18.4
EBIT margin %	6.6%	5.9%	0.7 pp
Book-to-bill	1.09	1.11	(1.3)
Backlog / Revs LTM	0.86	0.82	3.8

Air Traffic Management	2025	2024	Variation (%)
	(€m)	(€m)	Reported / Local currency
Backlog	1,052	855	23.1 / 24.4
Net Order Intake	726	586	23.9 / 25.5
Revenues	523	468	11.7 / 12.9
EBITDA	69	73	(6.2)
EBITDA Margin %	13.1%	15.6%	(2.5) pp
Operating Margin	55	60	(8.2)
Operating Margin %	10.5%	12.7%	(2.2) pp
EBIT	54	58	(8.0)
EBIT margin %	10.3%	12.5%	(2.2) pp
Book-to-bill	1.39	1.25	10.9
Backlog / Revs LTM	2.01	1.83	10.2

Mobility	2025	2024	Variation (%)
	(€m)	(€m)	Reported / Local currency
Backlog	1,014	959	5.8 / 7.5
Net Order Intake	469	411	14.0 / 16.1
Revenues	398	362	10.0 / 11.8
EBITDA	32	24	30.9
EBITDA Margin %	8.0%	6.7%	1.3 pp
Operating Margin	26	21	24.7
Operating Margin %	6.5%	5.7%	0.8 pp
EBIT	24	18	32.4
EBIT margin %	6.0%	5.0%	1.0 pp
Book-to-bill	1.18	1.14	3.7
Backlog / Revs LTM	2.55	2.65	(3.8)

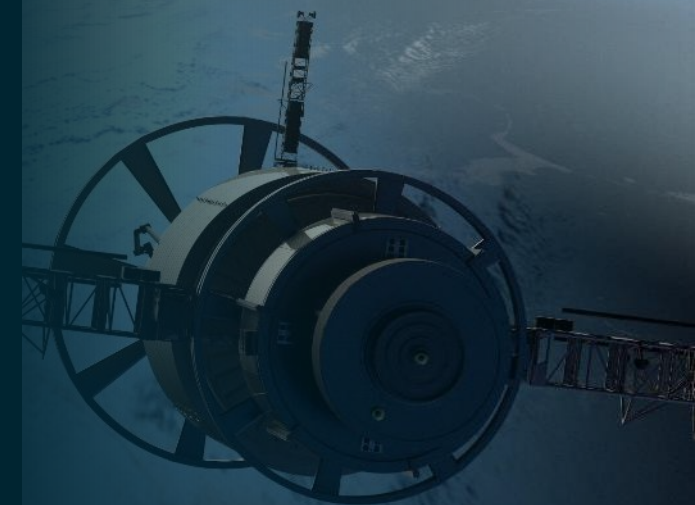

Key Workforce Figures

Employees by Region 2025

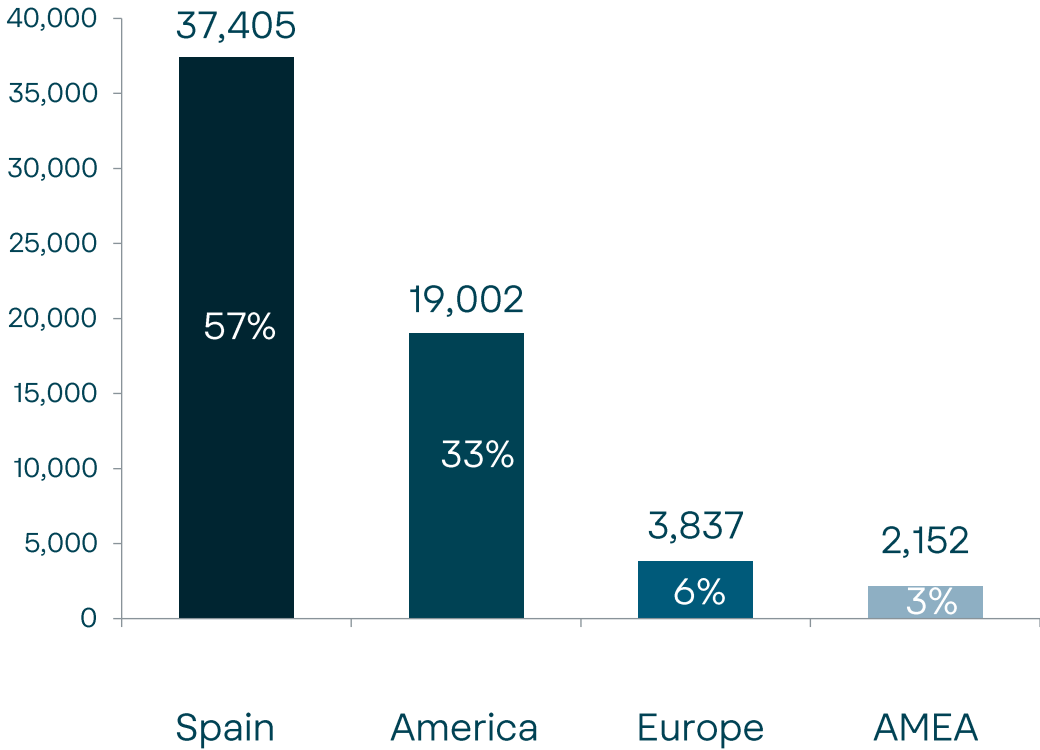

Employees by Division 2025

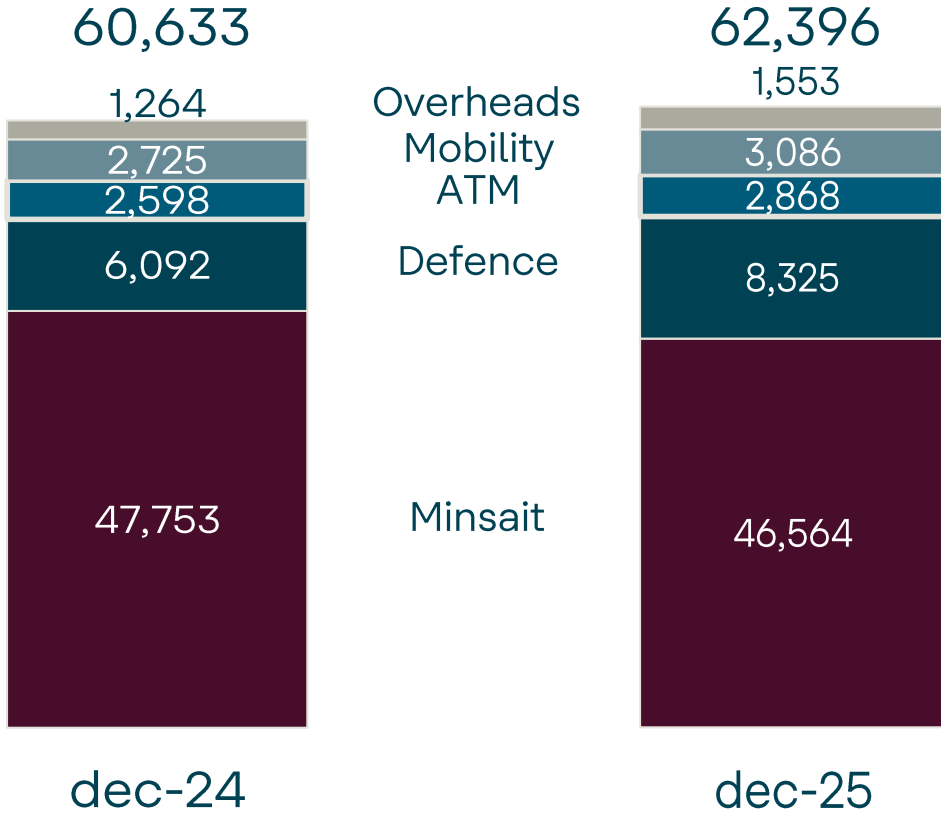

Main Shareholders

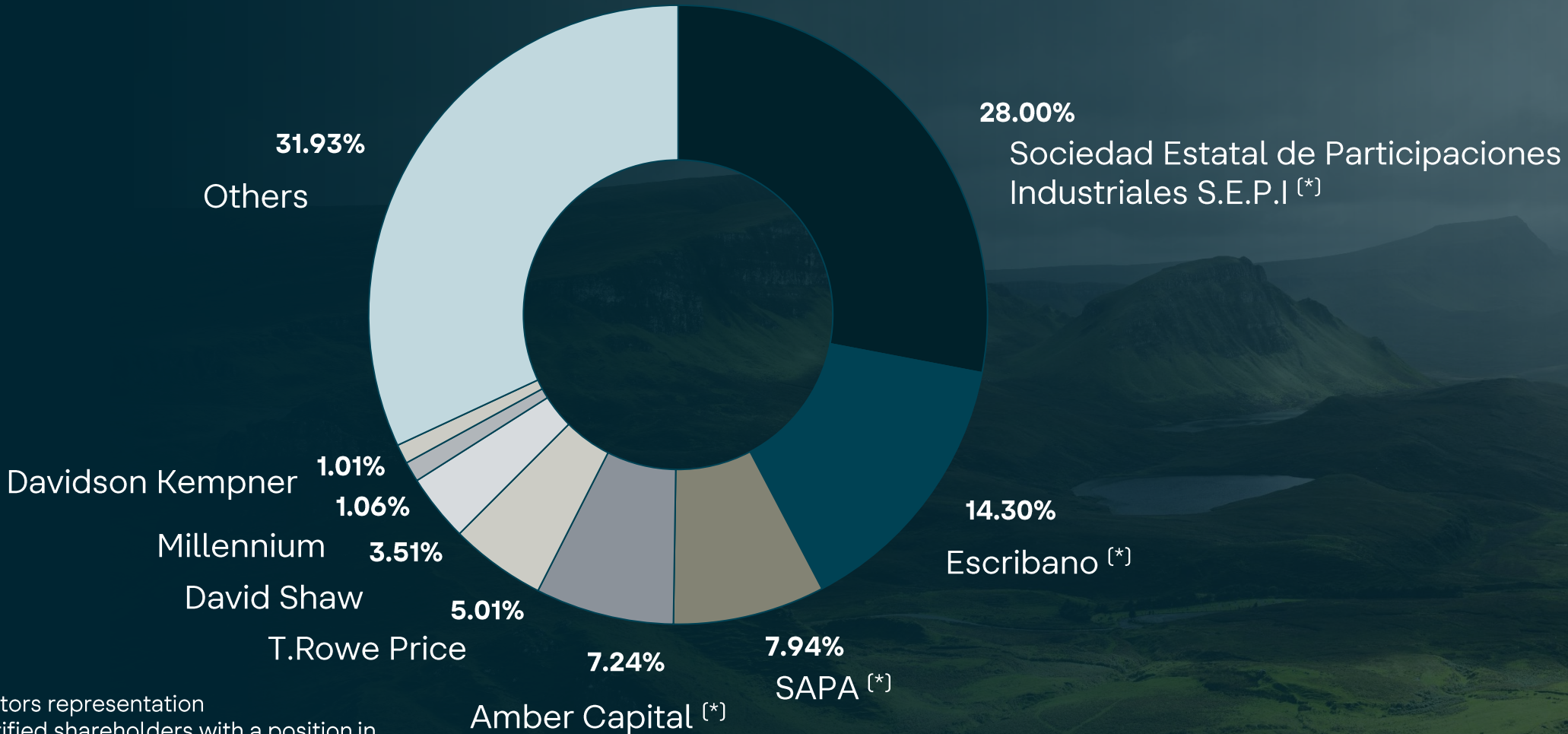

[*] Board of Directors representation
 CNMV data. Identified shareholders with a position in excess of 3%

Figures updated as of 02/03/2026

The data provided in this section includes the information provided by the shareholders to the Spanish National Securities Market Commission (CNMV), and with regard to the shareholders who are represented on the Board of Directors, the information which has been notified to the Company.

Significant Achievements in our ESG Strategy

Relevant presence in the main ESG indexes



S&P Dow Jones Indices
A Division of **S&P Global**

TOP 5%

Nº1 industry leader S&P Global CSA Score 2021, 2022 & 2023. Sustainability Award Gold Class 2022. Nº3 in 2024 and 2025.



A List

Leading climate action with first-class practices on climate change.



Gold Top 5%

Fulfilling most stringent environmental, labor practice and human rights requirements.



ESG Rating A

High performance on corporate governance, emissions and Clean Tech opportunities.



Low ESG Risk

Demonstrating strong management of ESG relevant issues. Qualified in 2025 as **Industry ESG Top Rated**



FTSE4Good Member

Member

Best score in governance, Human Rights, labor standards, and Climate Change

Committed to talent



Recognized as a **Top Employer** for 8 years in a row for the outstanding commitment to talent and career development, ethics and sustainability.

Acting on Climate Change



Net-Zero Target across the value chain by 2040 validated by SBTi.

- 2030: -90% scope 1 and 2 and -55% scope 3 emissions (intensity)
- 2040: -90% scope 1 and 2 and -97% scope 3 emissions (intensity)

Main Figures 2017-2025

	FY17	FY18	FY19	FY20	FY21	FY22	FY23	FY24	FY25
Backlog (€m)	3,612	4,065	4,511	5,229	5,459	6,309	6,776	7,245	16,083
Order Intake (€m)	3,248	3,437	3,686	3,858	3,714	4,778	4,583	5,356	12,778
Revenues (€m)	3,011	3,104	3,204	3,043	3,390	3,851	4,343	4,843	5,457
EBITDA (€m)	266	293	343	230 ⁽¹⁾	349 ⁽²⁾	400	446	545	636
EBIT (€m)	196	199	221	120 ⁽¹⁾	256 ⁽²⁾	300	347	438	517
EBIT margin	6.5%	6.4%	6.9%	4.0% ⁽¹⁾	7.5% ⁽²⁾	7.8%	8.0%	9.0%	9.5%
Net profit Reported (€m)	127	120	121	-65	143	172	206	278	436
CAPEX (€m) net of subsidies	40	79	76	39	-11	39	15	69	97
FCF (€m)	186	168	8	83	289	253	312	328	364
Net Debt (€m)	588	483	552	481	240	43	107	[86]	583

Strategic Plan Leading The Future

2030 Vision | A&D global Group leveraging Advanced Digital Technologies



Indra Land Vehicles

Progress in VCR & VAC¹ (TESS Defence)

Exploring further M&A to enhance and strengthen our capabilities

Indra Electronic Defence

Cutting-edge portfolio including Radar, Sensors, Electronic Warfare, Command, Control – C4i

Indra Weapons & Ammunition

Enhancing our competitive position through UAVs, C-UAS², Loitering Munition and Missiles

Alliances/ M&A as enabler

Indra Military Space

Key provider of secure communications, Earth and Space surveillance, positioning for military

Indra Civil Space

End-to-end secure communications, next-gen services, SSA & SST³ for governments and commercial customers

Indra Air Traffic Management

Boosting digital capabilities and air surveillance

Strengthening footprint in USA

Indra Mobility

Transforming the sector through digital offering: intelligent transport systems, multimodal solutions and connected vehicle

IndraMind

Artificial Intelligence for superiority in multidomain operations

Artificial Intelligence for automation of critical operations

Minsait

Evolving towards high value digital services and solutions

1. Combat Vehicle on Wheels & Army's Chain Support Vehicle; 2. Counter-Unmanned Aerial Systems; 3. Space Situational Awareness & Space Surveillance and Tracking

We are successfully implementing the strategic lines of the Strategic Plan *Leading the Future: Focus*

Business strategic lines

1. Aerospace & Defence



Industrial Plan



2. Space NewCo



3. Technology



Tech Operations

Cross-Group strategic lines

4. Strengthen presence in new 'home markets'

5. Activate portfolio rotation and expand the ecosystem

6. Increase investment in technological R&D

7. 'Double down' on critical talent

Indra Group continues its roadmap to become a leading player in Europe

Spain

Spain Defense Investment
2025 [€bn]

c. 33.0 

Investment in Special
Modernization Programs
[€bn]¹

c. 24.8 

Special Modernization
Programs awarded to
Indra Group^{1,2} [€bn]

c. 13.8

NATO



5% GDP

*in Defense and
Security by 2035*

 >4.7% current investment

 >3.5% starting in 2029

 >2.5% starting in 2027

1. Indra Group Defence Vision

8 Main Programmes from 24-26 Strategic Plan

FCAS

National Coordinator for NGWS programme, & international leader for the Sensors pillar

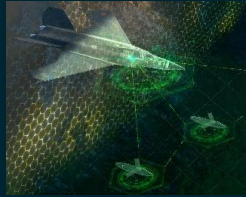

Eurofighter

Supply of next-generation Radar & Electronic Defence Systems



NH-90

Integration of Self-protection & Simulation Systems



A-400M

Supply of Surveillance & Self-Protection Systems



MKIII (Tiger)

Modernization of Tiger helicopters with Mission & Electronic Defence Systems



Chinook

Supply of Mission & Electronic Defence Systems



VCR 8x8

Integration of Mission & Situational Awareness Systems in ~350 vehicles



F110

Integration of Electronic Defence Systems & next-generation Sensors



PEM

Products to be delivered under 2025 Special Modernization Programs (PEMs)



Land vehicles



Radios

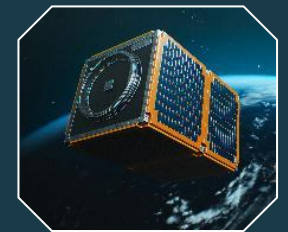

Satellites

Non exhaustive



C-UAS



Drones



Cyber defense



Radars

1. New 2025 PEM programs reinforce Indra pivotal role in the Spanish Defence industry

Government-approved¹ pre-financing lines

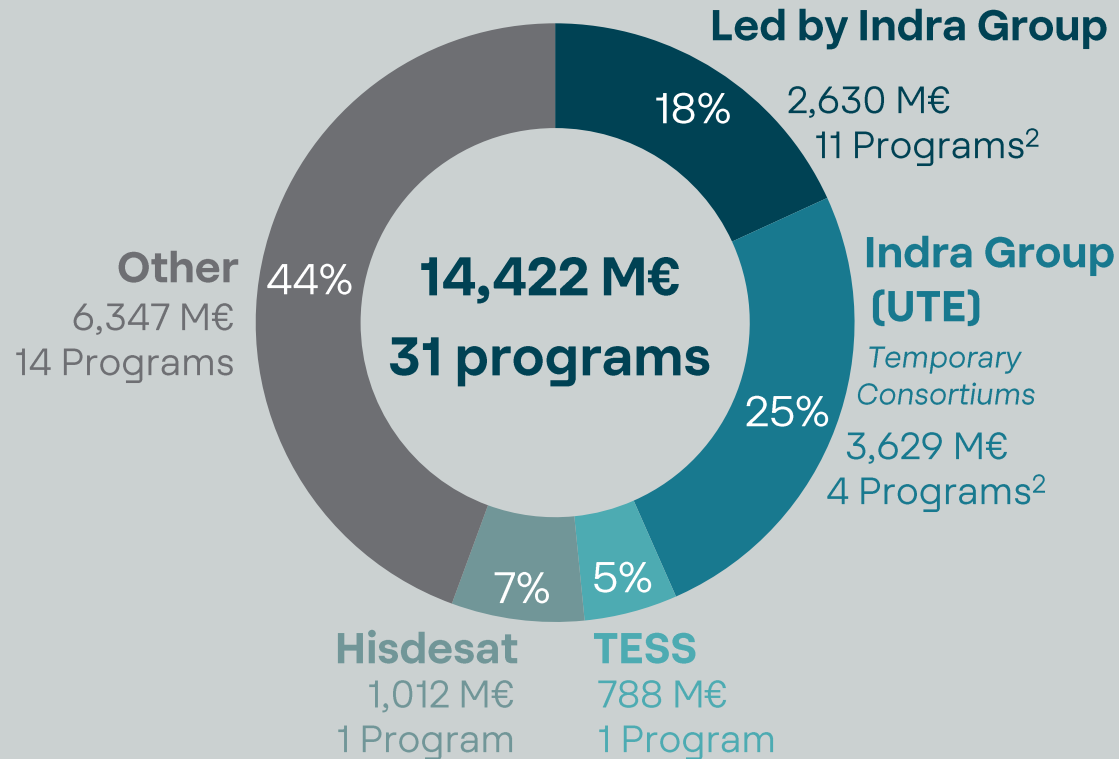

17 programs out of 31 led by Indra or Temporary Consortiums involving Indra – Additionally, Indra is positioned to take part in **12 additional** programs as subcontractor

Programs contract size

New Generation Weapon System (NGWS) ² – 540 M€
Counter-Battery Radars (RADAR – FI) – 25 M€
Classified Cyber Range (CYBER-RANGE) – 58 M€
Anti-Aircraft Artillery Operations Center System (COAAAS) – 1,687 M€
Joint Tactical Radio System (SCRT) – 1,174 M€
Wheeled Bridge-Laying Vehicle (VLP) – 316 M€
Comprehensive Advanced Cybersecurity System (SCOMCE) – 132 M€
Main Ground Combat System (MGCS) – 37 M€
Shipborne Launcher System (SLE) – 51 M€
Robotic Aerial Technologies for Sensorized Autonomous Mobility – 364 M€
Replacement of Legacy Systems in Electromagnetic Spectrum (REE-EW) – 308 M€

National Future Combat Air System (FCAS) ² – 160 M€
Counter Unmanned Aerial Systems (C-UAS) – 37 M€
Modernization of Command, Control & Communications Systems – 785 M€
Comprehensive Efficient Amphibious Projection System (VACIM) – 306 M€
Self-Propelled Howitzers (ATP) – 6,736 M€
Replacement of Legacy Systems in Electromagnetic Spectrum (REE-SCAPA) ³ – 16 M€

Tracked Support Vehicle (VAC) - ND

PAZ II Satellite Program – 1,090 M€

2. Indra Group Air Traffic Management Vision

Maintain **leadership** in Air Traffic Management in **Europe, Middle East and Latin America**

Reach the **number one position globally** by strengthening our core presence in **North America and Asia-Pacific**

Extend the **automation technological solution** to Middle East, Latin America and Asia



2. Indra will expand its European ATM leadership to other regions & market segments



Europe

European leadership consolidation

- Reinforce iTEC alliance, pushing forward new automation solutions
- Capture surveillance system renewal programmes



North America

Expansion of leadership to North America and Asia-Pacific/India

- Integration of acquisitions *[e.g. SELEX]* and scale-up with alliances & bolt-ons to strengthen positioning towards incoming U.S. programmes
- Capture large system renewal opportunities and develop Single Sky programmes and technology-partner-like alliances in Asia-Pacific



Asia-Pacific



UTM

Development of local unmanned traffic management platform and opportunities

[e.g. U-Space Service Provider]

3. Indra Group Space Vision

Tier-1 European referent with global footprint and leadership in main European programs

End-to-end capabilities along the value chain, with increasing focus on MEO/LEO initiatives

Dual civil-military offering for satellite secure communications, observation and navigation



3. Hispasat & Hisdesat acquisition | Integrated positioning across the value chain to deliver end-to-end Space missions

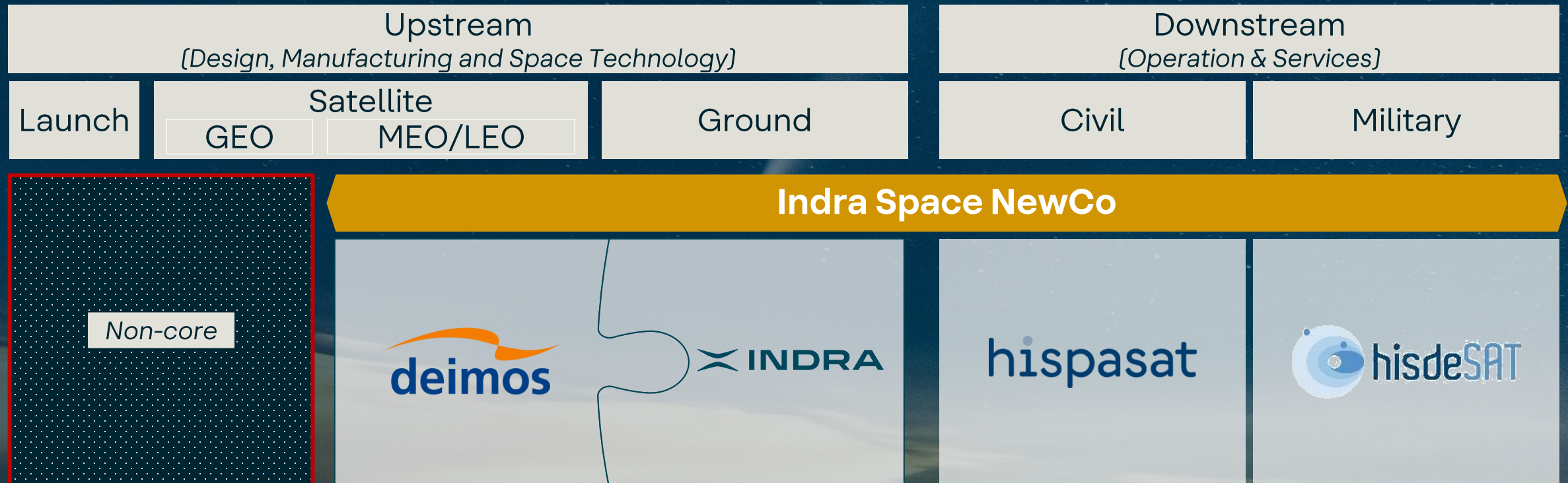

3. Indra Group has created Indra Space, its Space unit as committed in 2024

Capital Markets Day

Ambition to create a Space Unit with end-to-end

> €1,000 m

Revenue ambition 2030

24 months



Today

Indra Space is a European Space company, with end-to-end

>€375 m

Revenue 2025¹

>45%

EBITDA 2025¹

>€400 m

Budget 2026

Award of PEM Paz II for >€1,000 m

Future

High growth expectations

+50%

Increase in Spain's annual contribution to ESA² (period 2026-30 vs 2023-25)

4. Indra Group Minsait Vision

Become one of the **main European and Latin American IT Services players**

Aggressively rebalance portfolio towards most-advanced **digital business** lines

Accelerate expansion into **higher-value geographies**



4. AI advances are being leveraged to increase internal productivity and enhance product sophistication

AI in internal productive processes and corporate functions

Operations Tech

>10%

Revenue per employee in SW development

61%

Advanced use of AI in software development

Industrial Operations



Integration of AI in production plants

>10

Partnerships with hyperscalers and strategic partners

Enhancing the sophistication of Indra Group

> AI-based solutions to support our clients' decision-making

e.g. Predictive AI in insurers (loss-adjustment assessments), virtual assistants in airlines, detection of defective parts in assembly lines

> 6 use cases of IndraMind prioritized

Sovereign intelligence

Emergency Management

Drone swarms

Cyber Defense

Protection of Critical Infrastructure

Protection of sovereignty

> Evolution of the **Command and Control**

The **cross-cutting implementation of Tech Operations** has enabled the deployment of AI across the entire Indra Group

4. We have made progress in the evolution of Minsait

Evolution toward a portfolio of high-value solutions

- Decisive actions in the second half of the year
 - Divestment of **BPO**, non-core for Indra Group
 - **Reorganization** of **sales teams** (detailed account plans)
 - Commercial focus on **high-value solutions** (double-digit growth in Data, Cloud)

Cross-functional deployment of digital capabilities to serve all Indra Group Business Units

- **Operations Tech (+31,000 people):**
 - Technological evolution of the offering across all Indra Group businesses (e.g. Mobility)
 - Support for the award and delivery of Indra Group technology projects (e.g. Defense)
- Support in the **digitization** of Indra Group:
 - Supply chain (e.g., sensorization of production plants)
 - Corporate functions (e.g., finance)

Achieving an increase of **9.7%** in **revenue per employee**

IndraMind

"Delivering **advanced software & AI-driven solutions** that empower sophisticated **decision-making** and ensure reliability of **mission-critical operations**"

01

Build a **sovereign, advanced AI native platform**

02

Develop **customer-centric use cases** to cover needs from Spanish & European institutions and private companies

03

Bring together **advanced capabilities** (Data, Cyber...) to develop **cutting-edge tech**

4. IndraMind: Offering that covers all trends and all domains in both civil and military fields...

Trends in protection solutions

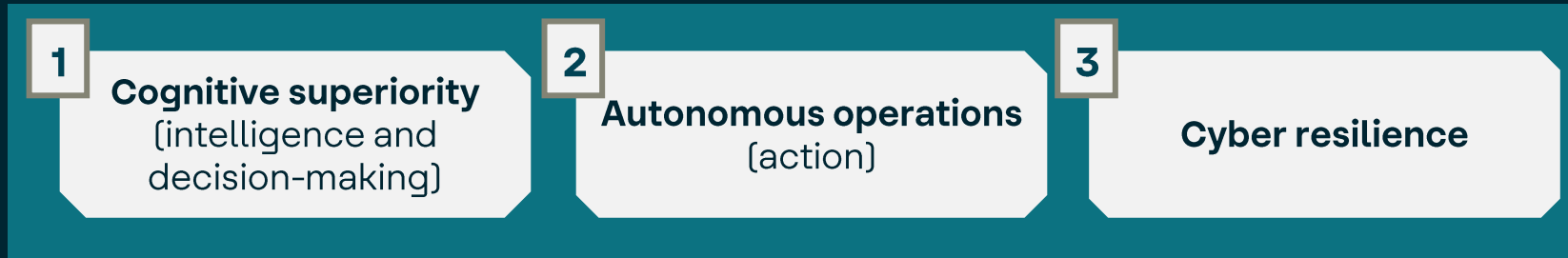

All domains

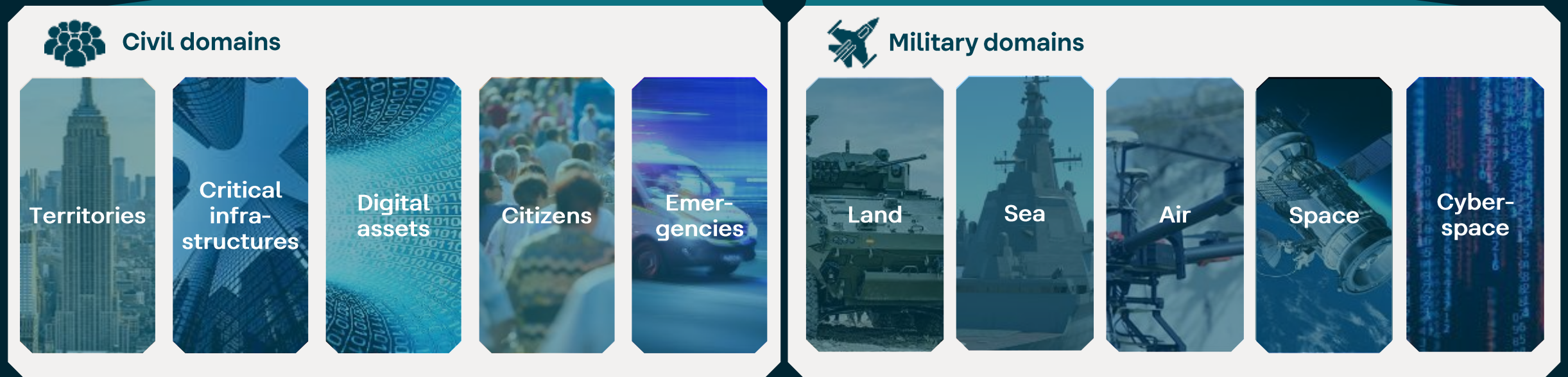

4. IndraMind aims to reach €1,000M+ revenue by 2030 to become a leader in Europe

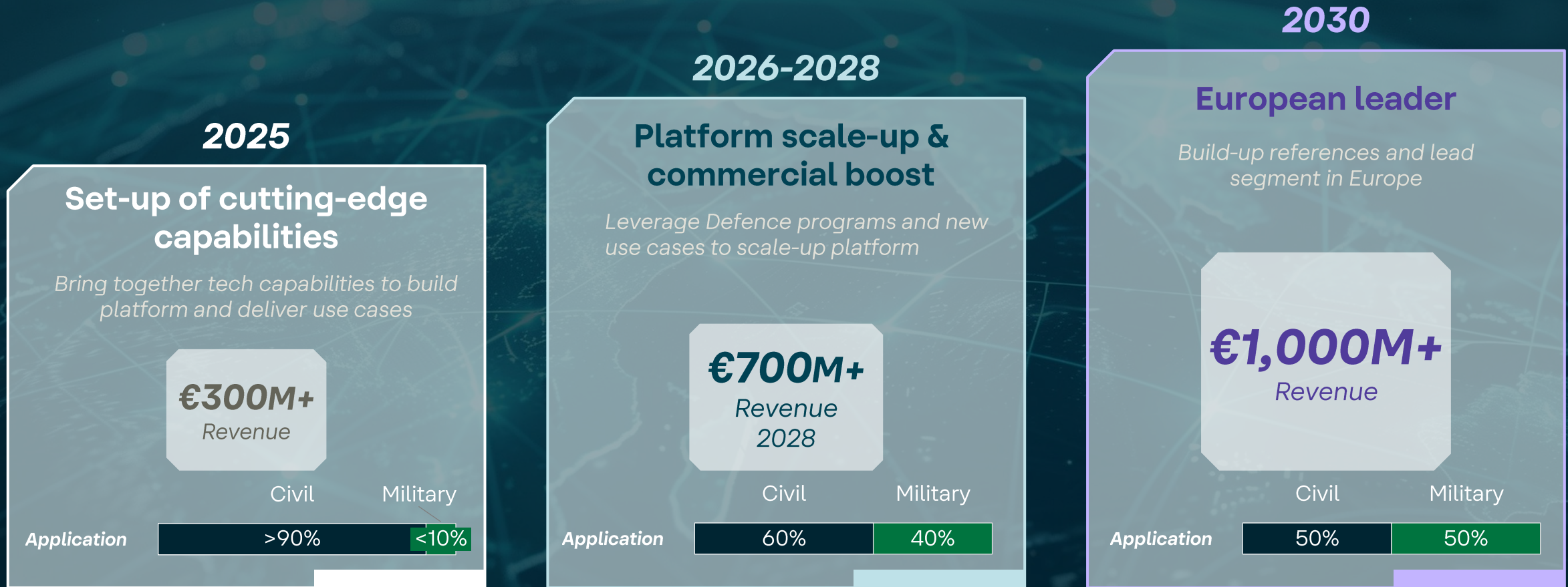





Expected growth: **25–30% CAGR**₂₅₋₃₀

5. The international business has been reviewed and simplified, facilitating international expansion



Reorganization of priority markets

Simplification from 27 to 19 organizational units

Europe 6

-  United Kingdom & Ireland
-  Germany
-  Norway
-  Italy
-  Poland
-  Brussels & EU

Middle East 3

-  Saudi Arabia
-  U.A.E. & PULSE (JV EDGE)
- Rest of Middle East

North America 2

-  U.S.
-  Canada

LatAm 4

-  Peru and Southern Cone
-  Col., & C.A and the Caribbean
-  Brazil
-  Mexico

Other commercial geographies 4

Main international contracts in 2025

Not exhaustive

North America

- Modernization of the FAA radar network in the U.S.
- Canada's NAV air simulators

Europe

- Ticketing TfL in the UK
- Space surveillance radars in Germany
- Ticketing public transport in Ireland
- Modernization of air traffic in the UK
- Modernization of air traffic in Belgium

Middle East

- Contract renewal ticketing for Haramain
- Radars in Oman
- Control towers at Abu Dhabi

LatAm

- Rail communications system in Chile
- Tolling systems and ITS¹ in Colombia
- Digital services for a bank in Brazil

Africa

- Maintenance of the Cairo metro
- Radars in Libya

Oceania

- Safe aviation radars in New Zealand

6. Ecosystem expansion

2025 M&A activity

The infographic is divided into three main sections:

- Acquisitions:** This section lists several companies with their logos and small circular icons indicating their origin. The companies include hispasat, hisdeSAT, Clue, AERTEC (Defence and Aerial Systems), WAKE, FYLA (WE LASER THE NEW INDUSTRY), TESS (DEFENCE), and GUARDIANUTM (OPERATING SYSTEM).
- 100+ Alliances and agreements:** This section features a grid of logos for various partners, including LEONARDO, PULSE, CALIDUS (خالدس), saes (Innovar_Desarrollar_Proteger), ELTGROUP, AIRTIFICIAL, LeciTrailer, FICOSA, BSC, and piedrafita.
- Divestments:** This section lists companies being divested, including gmv (INNOVATING SOLUTIONS), ARQUIMEA, NATS, S2GRUPO (Anticipando un mundo ciberseguro), Bittium, and AICOX. A large 'BPO' logo is also present, along with the text '+ Other divestments under analysis'.

A 'Non-exhaustive' label is placed at the top right of the central section.

Indra Group continues evaluating M&A opportunities to complete its capabilities

6. Indra Group continues to strengthen investment in R&D

Investment in R&D

€472 m

Investment in R&D 2025¹

€83 m

CapEx in engineering

8.7%

% of Revenue allocated to R&D

Priority technologies



Cyberdefense



Gallium Nitride



Photonics



Quantum



Applied AI

Collaborating with top-tier partners

400+ agreements with universities and vocational training centers



Advanced microelectronics design



uc3m

Quantum research and cryptography



Universidad de Alcalá

AI research and Computer vision



UNIVERSIDAD DE SEVILLA

Space tech. development with Big Data and AI

6. 4x increase in Indra Group's industrial footprint by 2027



1. It considers the jobs and the investment associated with the expansion of the footprint of production and of engineering

6. Indra Group has transformed its industrial DNA in 2025 to secure deliveries from 2026 onwards



**Expansion
of the footprint**

x4

**industrial
footprint** of Indra
Group 2027 vs.
2024



Increase in production

x2.5

production 2026 vs. 2024

- Product standardization
- Serial production
- Increase from 2 to 3 shifts in key products



**Tiering of the supply
chain**

450

Suppliers Tier 1 strategic

Excellence and full focus on industrial management

- Implementation of an industrial management mindset
- Deployment of a real-time digital platform for production and delivery tracking

6. We are making progress in the standardization and industrialization of our products



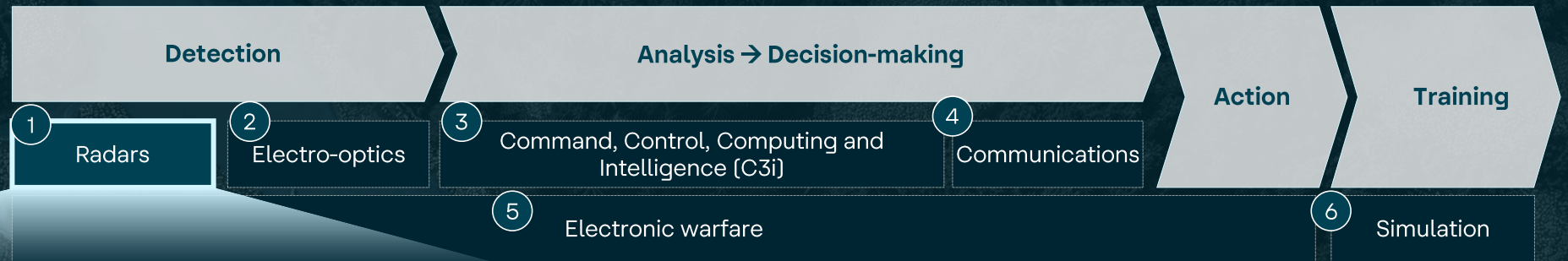



Capital Markets 2024:
"Focus on **6 technology categories** to develop 11 integrated solutions"



4 objectives set in the CMD 2024

x3	Annual units in production
+60%	Common elements across markets for the main radar families
13	Radar families in 2030 vs. 18 in 2025
50%	Reduction in production lead time

Progress made in priority radars

x4 ✓	In annual units produced	 LTR25  Nemus
+80% ✓	Common elements in the AESA radar family	 MTR  Nemus
14 ✓	Radar families in 2026 On track to reach the 2030 target	
50% ✓	Reduction in lead time with increased shifts and process optimization	 LTR25  Nemus

6. Indra Group has worked on tiering its supply chain

Supply chain driving role

78%



Defense procurement from Spanish suppliers

+70%

Increase in procurement spend volume vs. 2024, increasing +80% the average contracting per supplier

<450

Strategic Tier 1 suppliers that concentrate 90% of the spend in procurement the group's A&D

Cost reduction

Cost savings in procurement of key products

>10%



Nemus



PSR2D



PSR3D



LTR25

Forecast to double the savings with the consolidation of serial production

7. Indra is a reference in talent and we have increased both revenue and EBITDA per employee

Revenue per employee (€k)

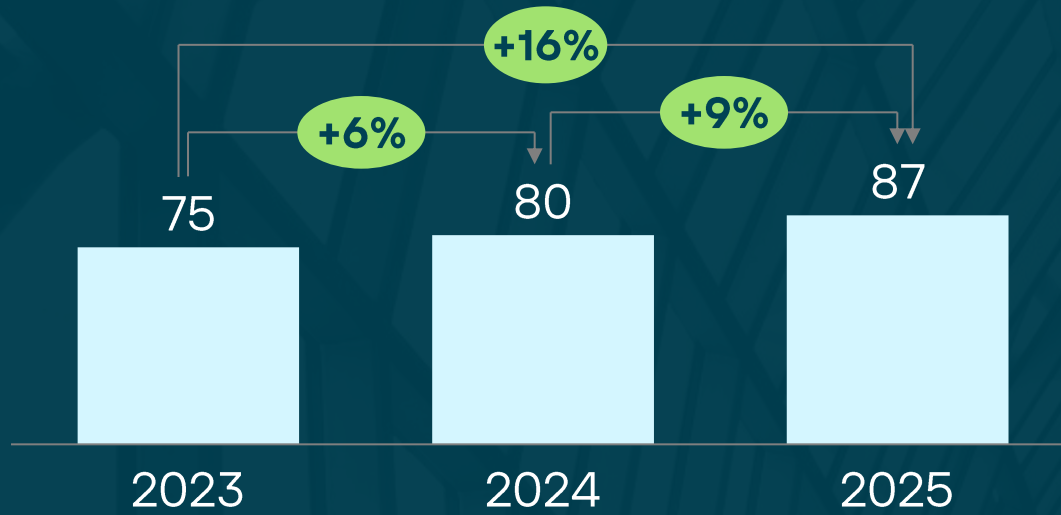

EBITDA/employee (€k)

2023	7.7	2024	9.0 [+16% vs '23]	2025	10.2 [+13% vs '24]
------	-----	------	----------------------	------	-----------------------

Employees (k)

2023	57.8	2024	60.6	2025	62.4
------	------	------	------	------	------

Indra Group is a reference in high-value talent

- **>2,400 jobs** in technology created in 2025
 - In line with the objective to create >5,000 high-value technology and digital jobs by 2026
- **3% workforce growth** vs 2024
 - 36% workforce growth in Defense in 2025
- Recognition as **Top Employer** for the 8th consecutive year
- Recognition by S&P as one of the **three most sustainable companies worldwide** – the only European company in the top 10

Financial projections

Leading The Future



2023

2026

2030

Revenues	€4.3B	€6B	€10B
EBITDA	10.3%	>12%	>14%
EBIT	8.0%	10%	12%
FCF	€0.9 B cumulative '24-'26	€2-2.5 B cumulative '27-'30	>€3 B '24-'30

Indra Group has consistently exceeded its targets since 2023

	Starting point	Strategic Plan Leading the Future: Focus				
	2023 Result	2024 Guidance	2024 Result	2025 Guidance ¹	2025 Result ²	2026 LtF Target ³
Revenue [€m]	4,343	4,650	4,843 ✓	5,200	5,457 ✓	>6,000
EBIT [€m]	347 [8.0%]	400 [8.6%]	438 ✓ [9.0%]	490 [9.4%]	517 ✓ [9.5%]	>600 [10%]
FCF [€m]	312	250	328 ✓	300	364 ✓	900 [cumulative '24-'26]

We are increasing our ambition for the 2026 Guidance

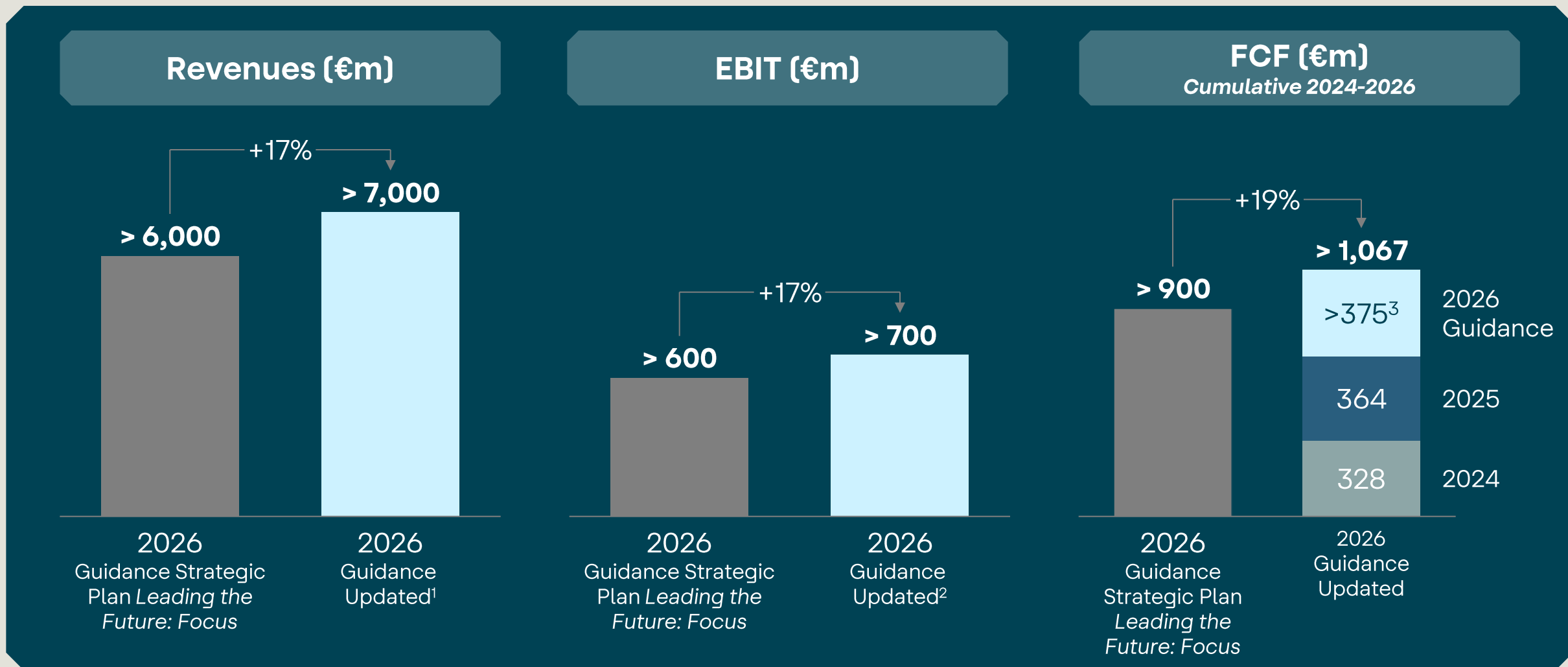

Capital Allocation Priorities



M&A Acceleration

Allocate >75% of acquisitions spend on Defence & Aerospace

Focus of M&A targets in Spain, Western Europe, Middle East & North America

M&A transactions will be aligned with strategy and growth story, **and** accretive for shareholders



Continued increase in technology investment

+€1.2 B technology spending until 2026

- ~€0.7 B programme-funded R&D spending
- ~€0.4 B other R&D spending
- ~€0.1 B Indra Technology Hub



Financial stability & greater shareholder returns

2026 Net Financial Debt / EBITDA of 1.0x – below industry peers – with a maximum threshold of up to 2.0x in '24-'26 period

Dividend practice in line with current payout ratios [~20%], consistent with company strategy



Anex I: Last Quarterly Results

FY25 Group Financial Results

Backlog¹

€16,083m

+122.0%

Order Intake

€12,778m

+138.6%

Revenues

€5,457m

+12.7%

EBITDA Margin

11.7%_(€636m +16.7% YoY)

+0.4pp

Operating Margin²

10.8%_(€591m +15.4% YoY)

+0.2pp

EBIT Margin

9.5%_(€517m +18.0% YoY)

+0.5pp

Net Income

€436m

+57.0%

Free Cash Flow

€364m

+11.0%

Net Debt³

€583m

1.0x Net Debt/EBITDA

1. Includes €1,429 from TESS Defence; 2. EBIT before Other Operating Income & Expenses, including: staff reorganization, impairments, capital gains, integration and acquisition costs, fines, amortization of intangible assets (PPA from acquisitions) and equity-based compensation; 3. Includes impact of the payment of Hispasat+Hisdesat, that did not contribute to EBITDA



Defence FY25

Backlog¹

€11,336m

+281.5%

Order Intake

€8,160m

+675.0%

Revenues

€1,407m

+36.4%

EBITDA Margin

18.4%_(€258m +25.0% YoY)

-1.6pp

Operating Margin²

17.1%_(€240m +25.6% YoY)

-1.4pp

EBIT Margin

16.5%_(€232m+24.5% YoY)

-1.5pp

Book-to-Bill

5.80x

1.02x in 2024

Backlog¹/Revs LTM

8.06x

2.88x in 2024

1. Includes €1,429m from TESS Defence; 2. EBIT before Other Operating Income & Expenses, including: staff reorganization, impairments, capital gains, integration and acquisition costs, fines, amortization of intangible assets (PPA from acquisitions) and equity-based compensation.

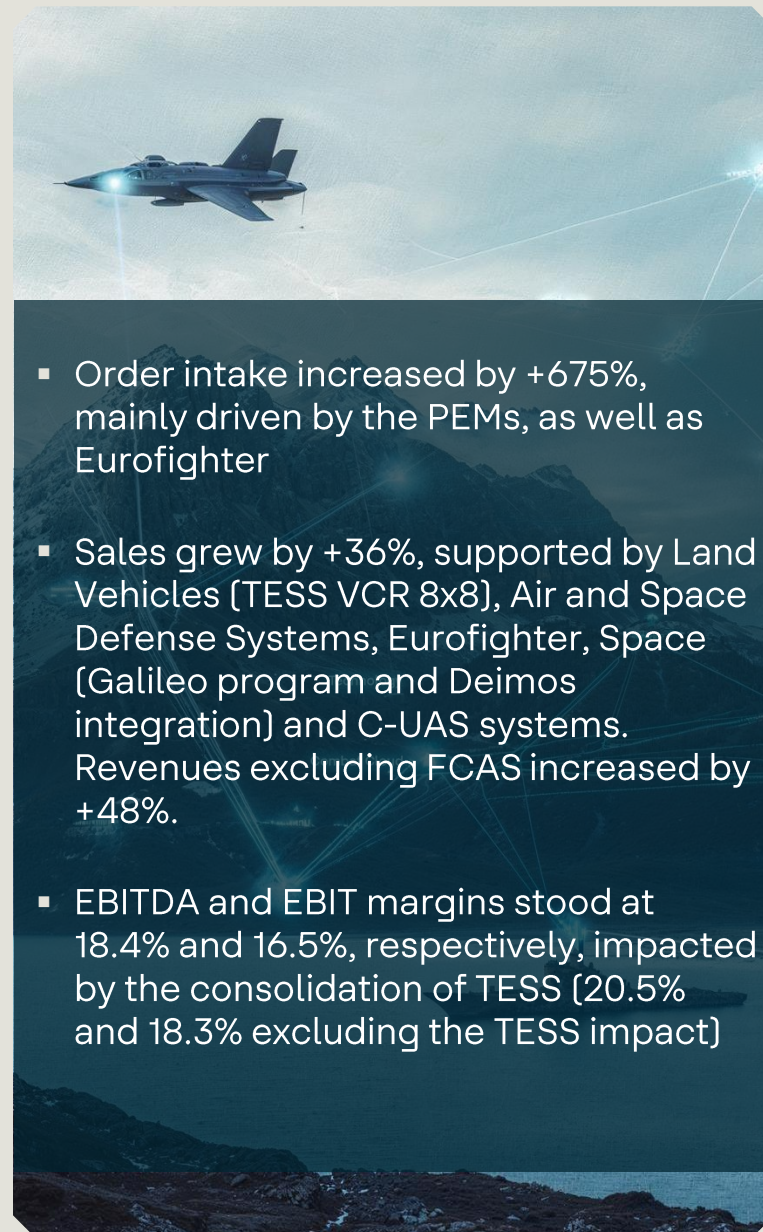

- Order intake increased by +675%, mainly driven by the PEMs, as well as Eurofighter
- Sales grew by +36%, supported by Land Vehicles (TESS VCR 8x8), Air and Space Defense Systems, Eurofighter, Space (Galileo program and Deimos integration) and C-UAS systems. Revenues excluding FCAS increased by +48%.
- EBITDA and EBIT margins stood at 18.4% and 16.5%, respectively, impacted by the consolidation of TESS (20.5% and 18.3% excluding the TESS impact)

Air Traffic Management FY25

Backlog

€1,052m

+23.1%

Order Intake

€726m

+23.9%

Revenues

€523m

+11.7%

EBITDA Margin

13.1%_(€69m -6.2% YoY)

-2.5pp

Operating Margin¹

10.5%_(€55m -8.2% YoY)

-2.2pp

EBIT Margin

10.3%_(€54m -8.0% YoY)

-2.2pp

Book-to-Bill

1.39x

1.25x in 2024

Backlog/Revs LTM

2.01x

1.83x in 2024

1. EBIT before Other Operating Income & Expenses, including staff reorganization, impairments, capital gains, integration and acquisition costs, fines, amortization of intangible assets (PPA from acquisitions) and equity-based compensation;

- Presence across 5 continents, with the ambition to become the most innovative ATM company globally
- Order intake increased by +24%, driven by radar contracts in the UK and Azerbaijan, as well as the radio renewal contract in the U.S.
- Sales grew by +12%, supported by the U.S. radio systems contract and Canada (iTEC), and radar contracts in the UK
- EBITDA and EBIT margins stood at 13.1% and 10.3%, impacted by an exceptional write-down of an aeronautical information systems project in Central Europe, as incomplete assets were deemed non-recoverable following changes in project scope. Excluding this impact, EBITDA and EBIT margins would have been 15.6% and 12.7%, respectively

Mobility FY25

Backlog

€1,014m

+5.8%

Order Intake

€469m

+14.0%

Revenues

€398m

+10.0%

EBITDA Margin

8.0%_(€32m +30.9% YoY)

+1.3pp

Operating Margin¹

6.5%_(€26m +24.7%)

+0.8pp

EBIT Margin

6.0%_(€24m +32.4%)

+1.0pp

Book-to-Bill

1.18x

1.14x in 2024

Backlog/Revs LTM

2.55x

2.65x in 2024

1. EBIT before Other Operating Income & Expenses, including staff reorganization, impairments, capital gains, integration and acquisition costs, fines, amortization of intangible assets (PPA from acquisitions) and equity-based compensation;

- Order intake increased by +14%, driven by railway maintenance contracts in Chile, urban traffic management in Ireland, tolling systems in Colombia, ticketing in Saudi Arabia, and the Cairo metro maintenance contract in Egypt
- The TfL agreement (€1.0bn in order intake) is not included in FY25 results
- Presence in 5 U.S. states, confirming strong performance in the country, reinforced by the Toll Excellence Award received for Virginia's highway technology
- Sales increased by +10%, with strong growth across all regions except the Americas
- EBITDA and EBIT margins improved to 8.0% and 6.0%, respectively

Minsait FY25

Backlog

€2,681m

+9.0%

Order Intake

€3,424m

+3.6%

Revenues

€3,129m

+4.9%

EBITDA Margin

8.9%_(€277m +15.2% YoY)

+0.8pp

Operating Margin¹

8.6%_(€270m +12.4% YoY)

+0.5pp

EBIT Margin

6.6%_(€208m +18.4% YoY)

+0.7pp

Book-to-Bill

1.09x

1.11x in 2024

Backlog/Revs LTM

0.86x

0.82x in 2024

1. EBIT before Other Operating Income & Expenses, including staff reorganization, impairments, capital gains, integration and acquisition costs, fines, amortization of intangible assets (PPA from acquisitions) and equity-based compensation;

- 
- New leadership at Minsait, accelerating growth and margin improvement in 2H'25 vs. 1H'25
 - Order intake increased by +3.6% (vs. +2.5% in 1H'25), mainly driven by Public Administrations & Healthcare [+20%] and Energy & Industry [+5%]
 - Revenues grew by +4.9% (vs. +1.5% in 1H'25), with growth across all divisions except Telecom & Media
 - Acceleration in margin improvement: +0.8pp in EBITDA and +0.7pp in EBIT (vs. +0.5pp and +0.4pp in 1H'25)

FY25 FCF Generation

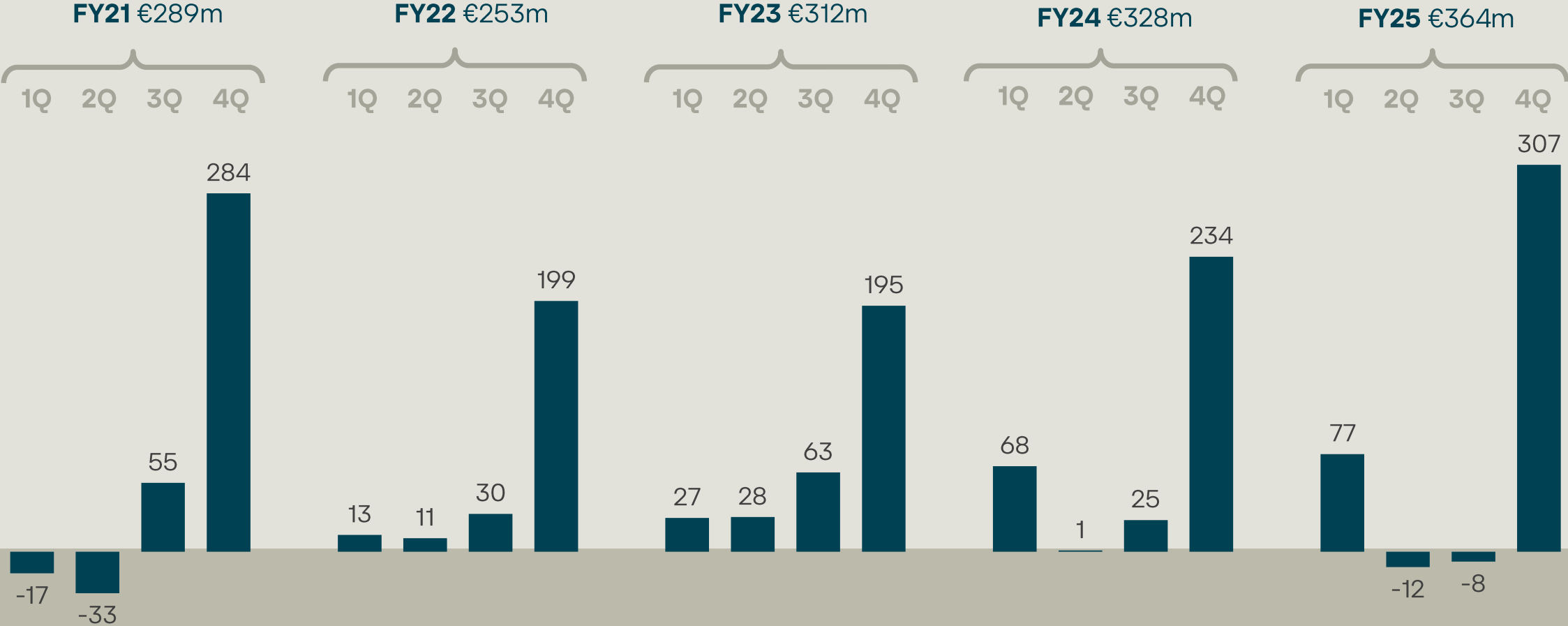

Quarterly reported FCF (€m)

Net Working Capital Evolution

Net Working Capital ST+LT (DoS)

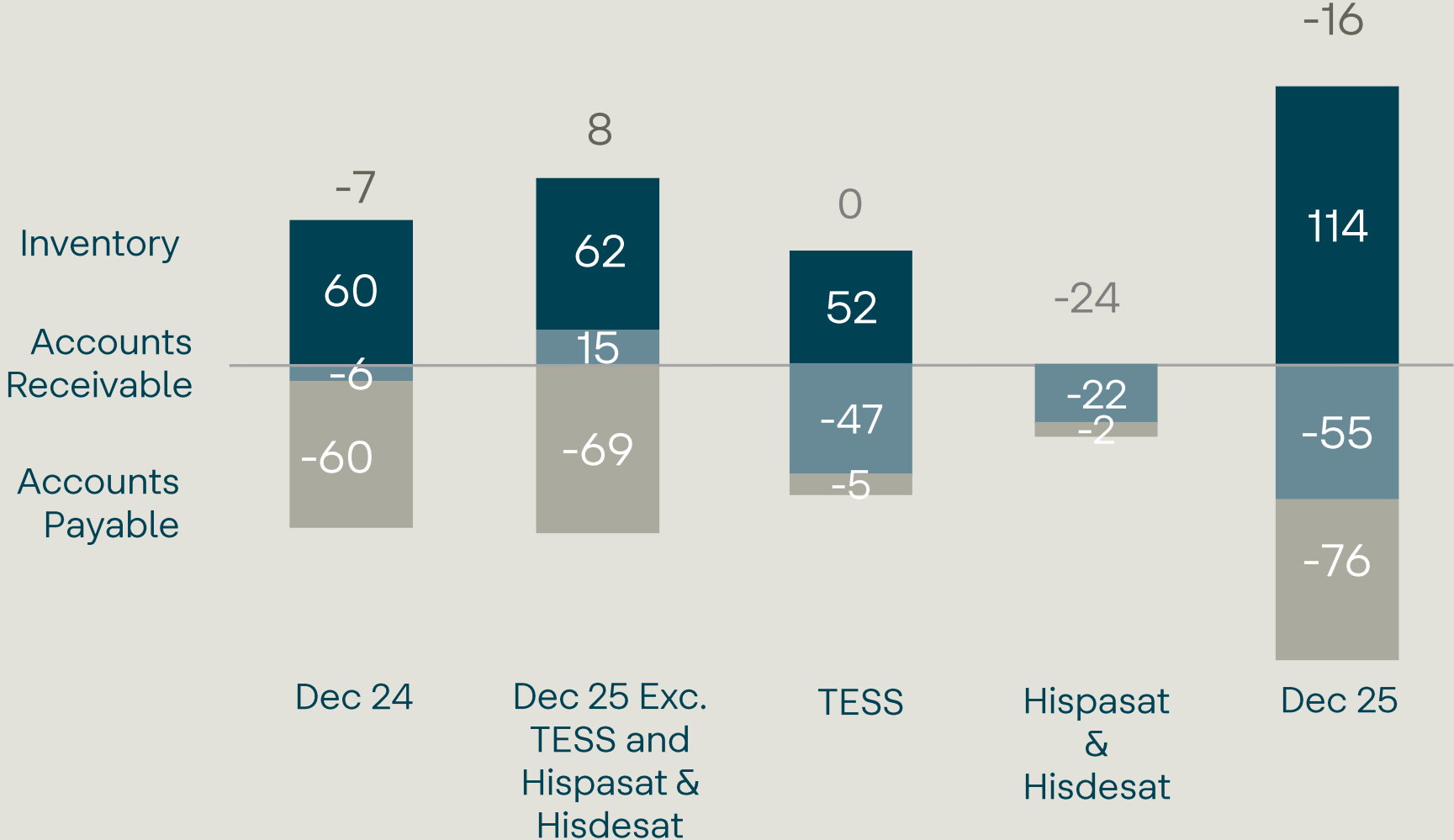

FY25 Net Debt bridge

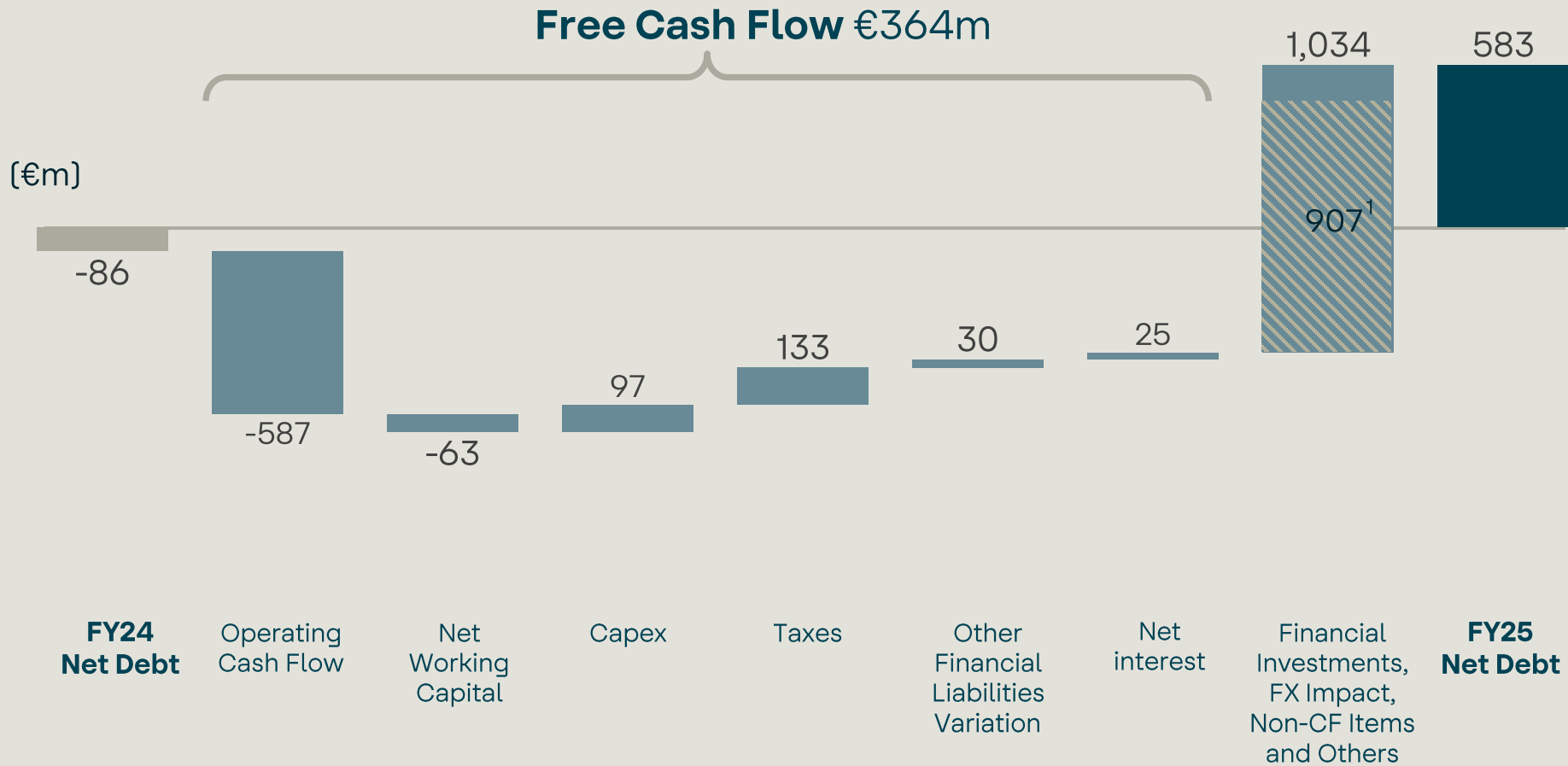

1. Acquisitions of 907M€, including 725M€ from de acquisition of Hispasat and Hisdesat and 107M€ from TESS

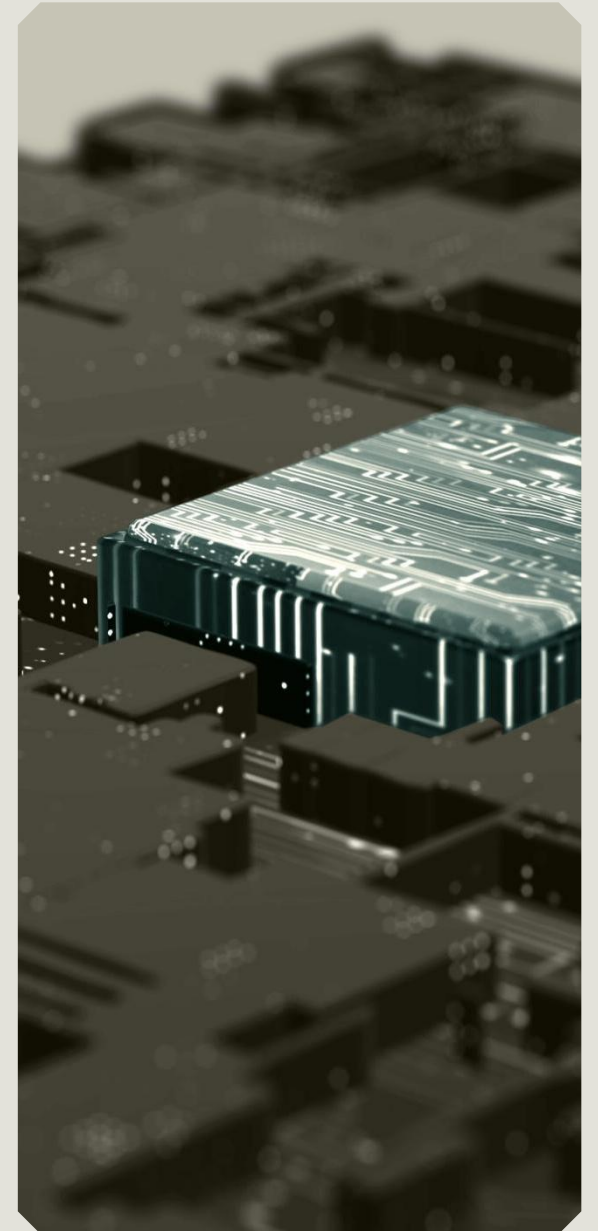

Net Debt/EBITDA Evolution

Net Debt (€m)

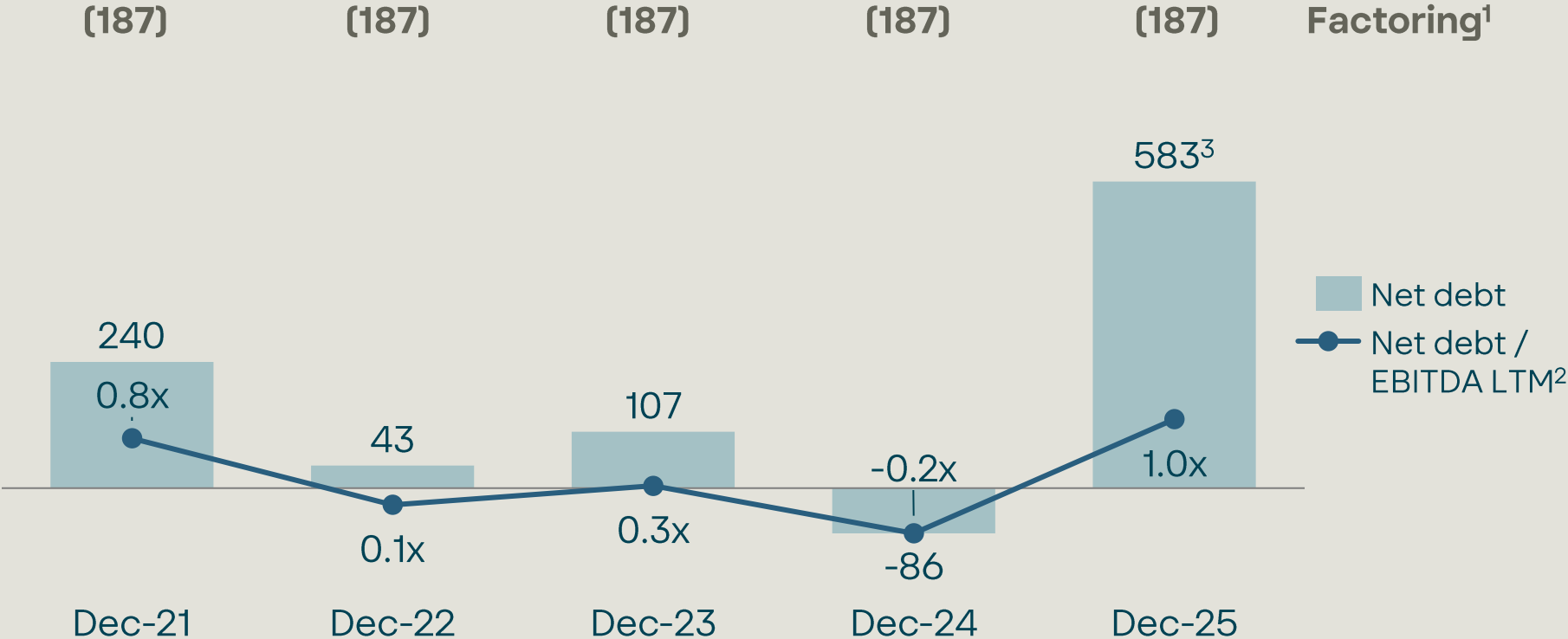

1. Non-recourse factoring; 2. EBITDA LTM excluding IFRS 16, extraordinary items related to employee restructuring plans; 3. Includes impact of the payment of Hispasat+Hisdesat, that did not contribute to EBITDA



Diversified Debt Structure

Gross and Net Debt Structure

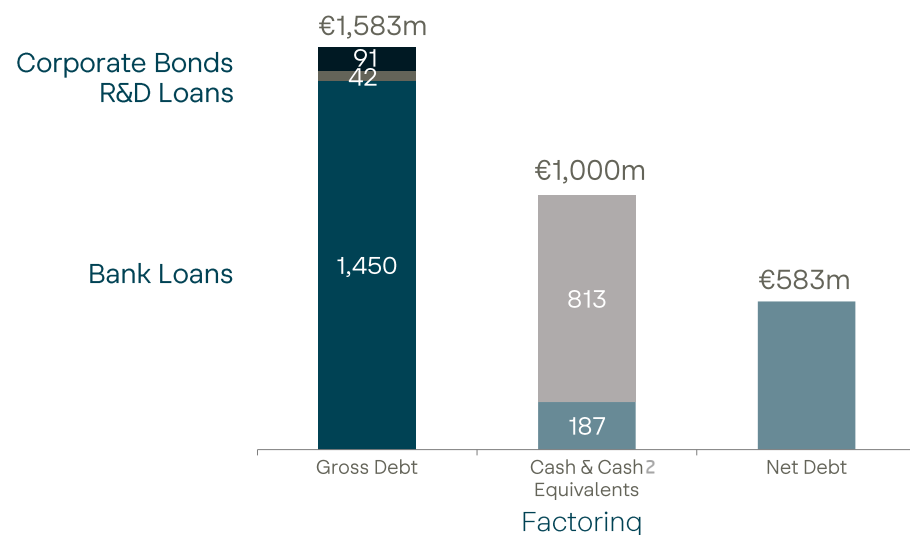

Other available credit facilities: €1,175¹m

	FY25	FY24
Average life (years)	3.1	1.3

Gross Debt Maturity Profile

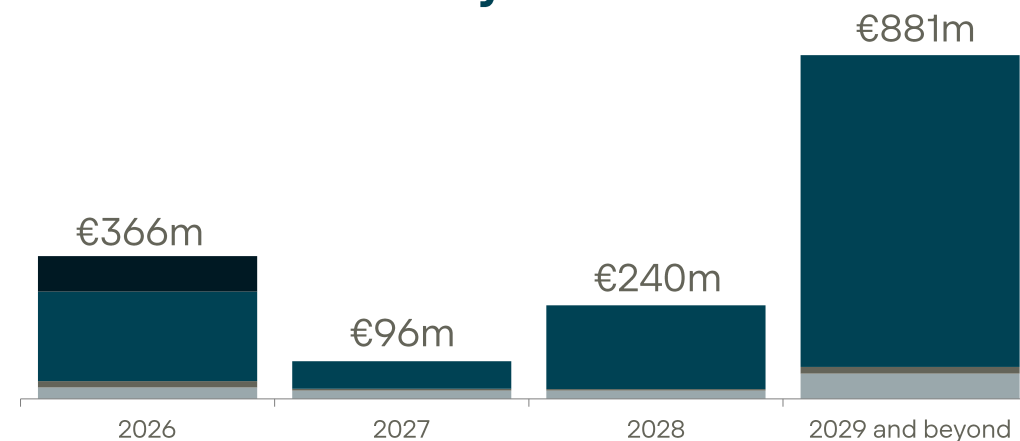

	(€m)	FY25	% total	FY24	% total
L/T Debt		1,197	76%	343	65%
S/T Debt		386	24%	186	35%
Gross Debt		1,583	100%	530	100%
Cost of Gross Debt		3.1%		4.2%	
Cash & Others before transfer to held for sale		976	n.m.	555	n.m.
Cash & Others after transfer to held for sale		1,000		616	
Net Debt		583	n.m.	-86	n.m.

1. Includes €385m EIB Facility with defined use of proceeds 2. Cash & Others after transfer to held for sale.

*The gross debt of Hispasat amounted €137m and cash from Hispasat & Hisdesat amounted €119m

