

# Investors Presentation

May 2026

Leading the Future

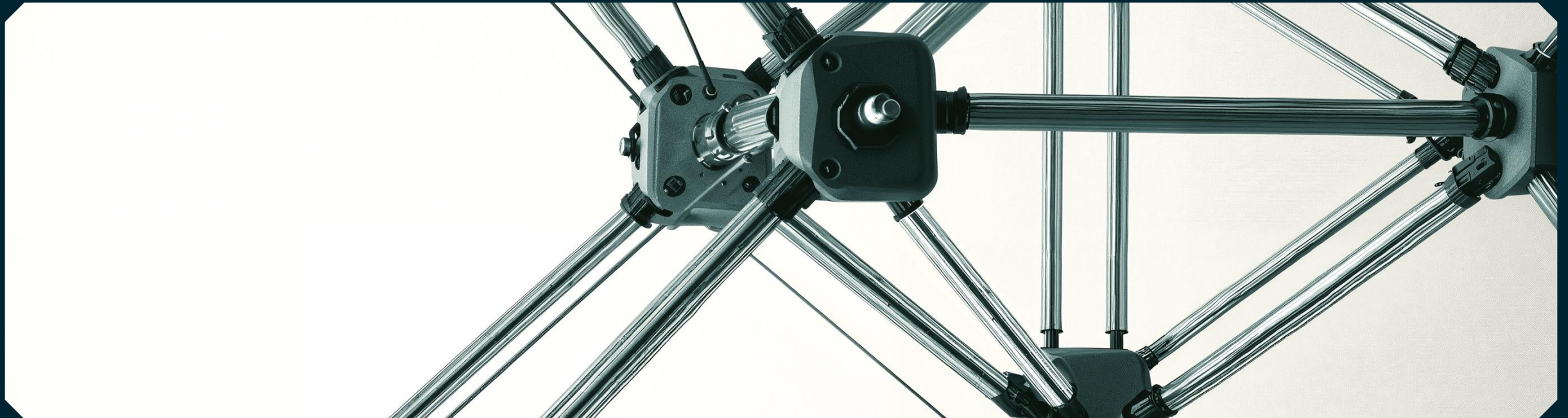

# 01

OVERVIEW

# 02

STRATEGIC  
PLAN LEADING  
THE FUTURE

# 03

FINANCIAL  
PROJECTIONS

# 04

ANNEX 1Q26  
RESULTS

This presentation has been produced by Indra for the sole purpose expressed therein. Therefore, neither this presentation nor any of the information contained herein constitutes an offer sale or exchange of securities, invitation to purchase or sale shares of the Company or any advice or recommendation with respect to such securities.

Its content is purely for information purposes and the statement it contains may reflect certain forward-looking statements, expectations and forecasts about the Company at the time of its elaboration. These expectations and forecasts are not in themselves guarantees of future performance as they are subject to risks, uncertainties and other important factors beyond the control of the Company that could result in final

results materially differing from those contained in these statements. The Company does not assume any obligation or liability in connection with the accuracy of the mentioned estimations and is not obliged to update or revise them.

This document contains information that has not been audited. In this sense, this information is subject to, and must be read in conjunction with, all other publicly available information.

This disclaimer should be taken into consideration by all the individuals or entities to whom this document is targeted and by those who consider that they have to make decisions or issue opinions related to securities issued by Indra.



# Overview

---

# Indra's Vision and Main 2025 Figures

Become the Spanish multinational of reference in Defence & Aerospace and Advanced Digital Technologies



Revenues 2025  
€5.5Bn

EBITDA 2025  
€636m  
EBITDA margin  
11.7%

EBIT 2025  
€517m  
EBIT margin  
9.5%

>140  
Countries

~62,000  
Employees

€472m  
In R&D

# Breakdown by Geography and Division

### FY25 Revenues breakdown by Geography

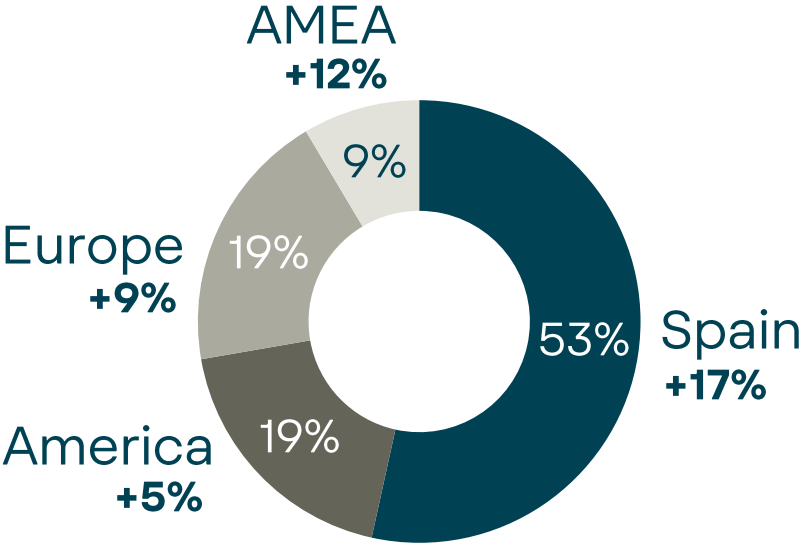

International Business covering 47%

### FY25 EBITDA breakdown by Division

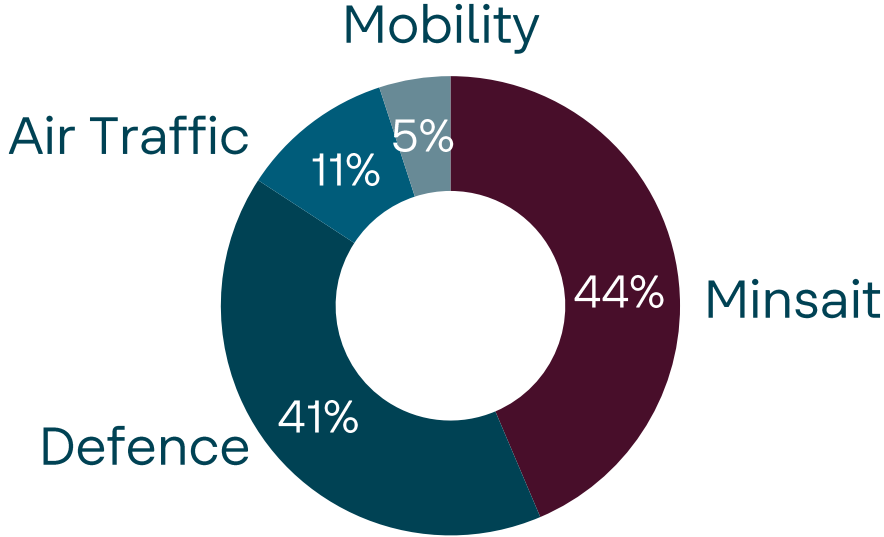

Defence, ATM and Mobility EBITDA account for 56% of total

# Main Figures by Division

<b>Defence</b>	<b>2025</b>	<b>2024</b>	<b>Variation (%)</b>
	(€m)	(€m)	Reported / Local currency
<b>Backlog</b>	11,336	2,972	281.5 / 281.6
<b>Net Order Intake</b>	8,160	1,053	675.0 / 675.2
<b>Revenues</b>	1,407	1,031	36.4 / 36.5
<b>EBITDA</b>	258	207	25.0
<b>EBITDA Margin %</b>	18.4%	20.0%	(1.6) pp
<b>Operating Margin</b>	240	191	25.6
<b>Operating Margin %</b>	17.1%	18.5%	(1.4) pp
<b>EBIT</b>	232	186	24.5
<b>EBIT margin %</b>	16.5%	18.0%	(1.5) pp
<b>Book-to-bill</b>	5.80	1.02	468.2
<b>Backlog / Revs LTM</b>	8.06	2.88	179.7

<b>Minsait</b>	<b>2025</b>	<b>2024</b>	<b>Variation (%)</b>
	(€m)	(€m)	Reported / Local currency
<b>Backlog</b>	2,681	2,460	9.0 / 11.5
<b>Net Order Intake</b>	3,424	3,306	3.6 / 5.6
<b>Revenues</b>	3,129	2,982	4.9 / 7.0
<b>EBITDA</b>	277	241	15.2
<b>EBITDA Margin %</b>	8.9%	8.1%	0.8 pp
<b>Operating Margin</b>	270	240	12.4
<b>Operating Margin %</b>	8.6%	8.1%	0.5 pp
<b>EBIT</b>	208	176	18.4
<b>EBIT margin %</b>	6.6%	5.9%	0.7 pp
<b>Book-to-bill</b>	1.09	1.11	(1.3)
<b>Backlog / Revs LTM</b>	0.86	0.82	3.8

<b>Air Traffic Management</b>	<b>2025</b>	<b>2024</b>	<b>Variation (%)</b>
	(€m)	(€m)	Reported / Local currency
<b>Backlog</b>	1,052	855	23.1 / 24.4
<b>Net Order Intake</b>	726	586	23.9 / 25.5
<b>Revenues</b>	523	468	11.7 / 12.9
<b>EBITDA</b>	69	73	(6.2)
<b>EBITDA Margin %</b>	13.1%	15.6%	(2.5) pp
<b>Operating Margin</b>	55	60	(8.2)
<b>Operating Margin %</b>	10.5%	12.7%	(2.2) pp
<b>EBIT</b>	54	58	(8.0)
<b>EBIT margin %</b>	10.3%	12.5%	(2.2) pp
<b>Book-to-bill</b>	1.39	1.25	10.9
<b>Backlog / Revs LTM</b>	2.01	1.83	10.2

<b>Mobility</b>	<b>2025</b>	<b>2024</b>	<b>Variation (%)</b>
	(€m)	(€m)	Reported / Local currency
<b>Backlog</b>	1,014	959	5.8 / 7.5
<b>Net Order Intake</b>	469	411	14.0 / 16.1
<b>Revenues</b>	398	362	10.0 / 11.8
<b>EBITDA</b>	32	24	30.9
<b>EBITDA Margin %</b>	8.0%	6.7%	1.3 pp
<b>Operating Margin</b>	26	21	24.7
<b>Operating Margin %</b>	6.5%	5.7%	0.8 pp
<b>EBIT</b>	24	18	32.4
<b>EBIT margin %</b>	6.0%	5.0%	1.0 pp
<b>Book-to-bill</b>	1.18	1.14	3.7
<b>Backlog / Revs LTM</b>	2.55	2.65	(3.8)

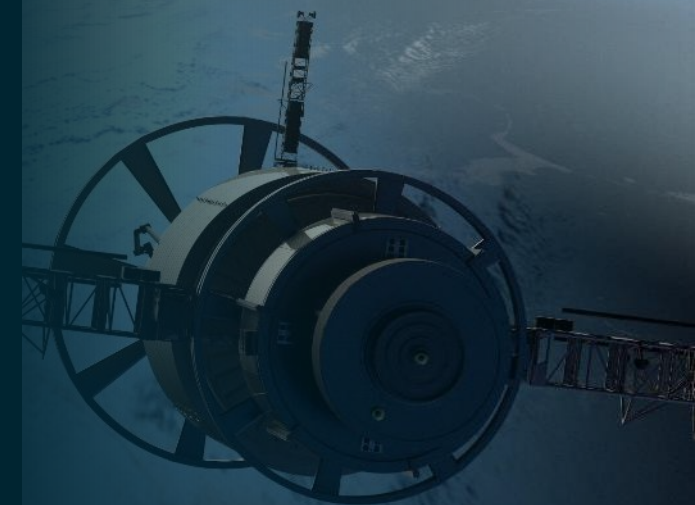

# Key Workforce Figures

### Employees by Region 2025

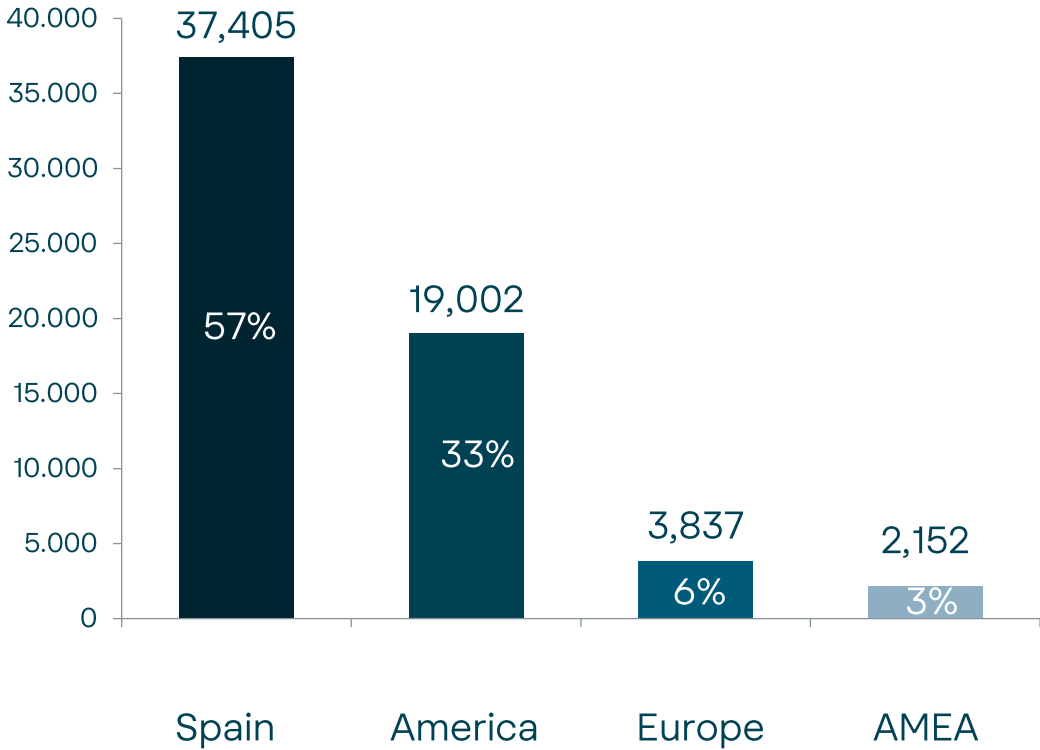

### Employees by Division 2025

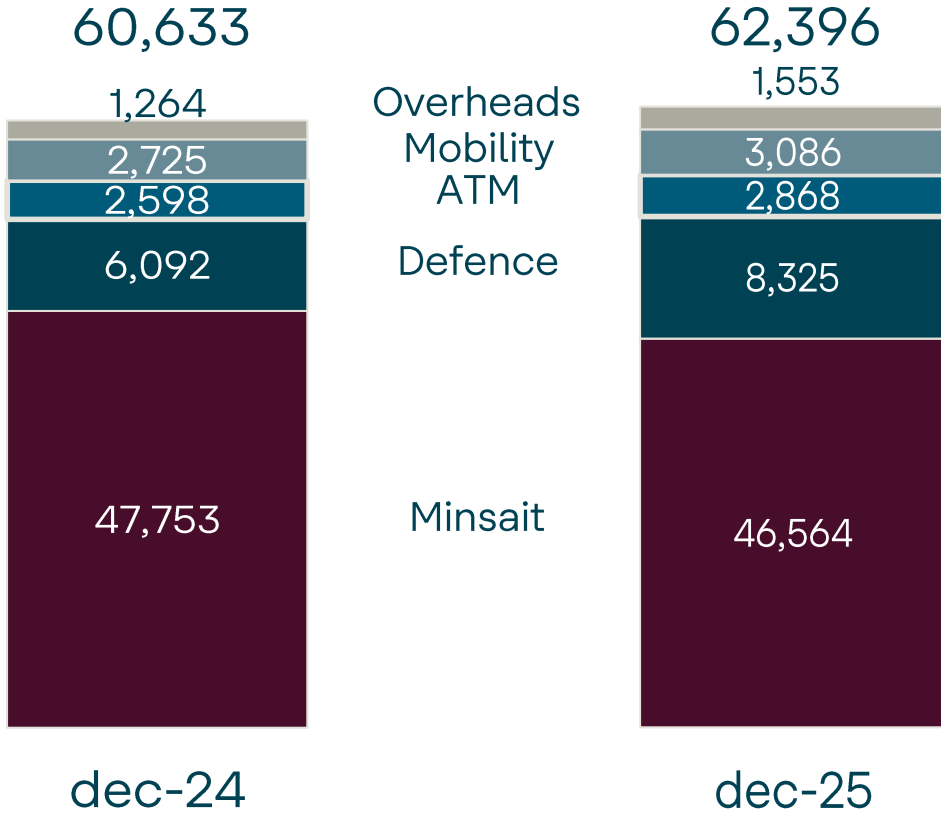

# Main Shareholders

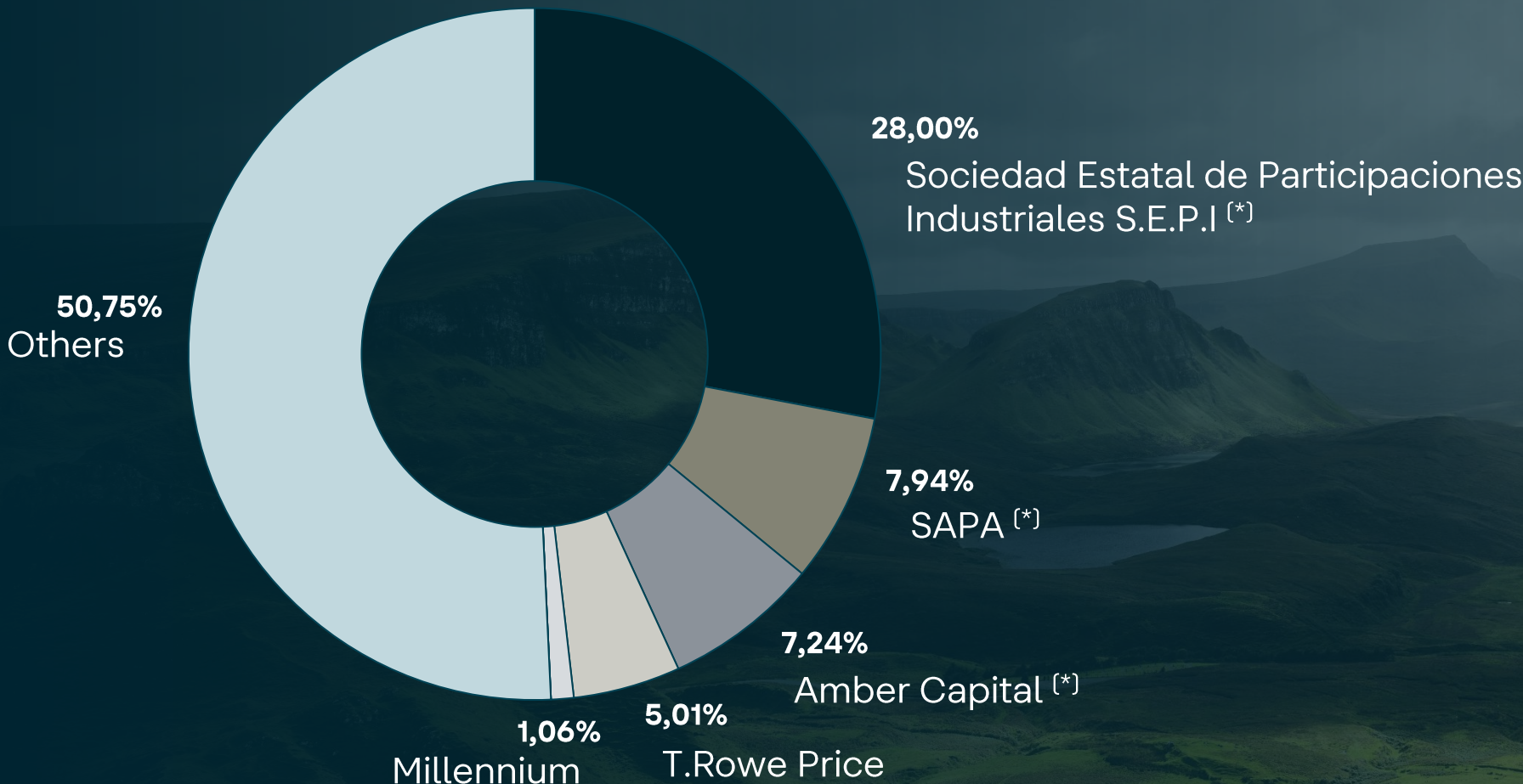

[\*] Board of Directors representation  
CNMV data. Identified shareholders with a position in excess of 3%

Figures updated as of 26/05/2026

The data provided in this section includes the information provided by the shareholders to the Spanish National Securities Market Commission (CNMV), and with regard to the shareholders who are represented on the Board of Directors, the information which has been notified to the Company.

# Significant Achievements in our ESG Strategy

## Relevant presence in the main ESG indexes



**S&P Dow Jones Indices**  
A Division of **S&P Global**

### TOP 5%

Nº1 industry leader S&P Global CSA Score 2021, 2022 & 2023. Sustainability Award Gold Class 2022. Nº3 in 2024 and 2025.



### A List

Leading climate action with first-class practices on climate change.



### Gold Top 5%

Fulfilling most stringent environmental, labor practice and human rights requirements.



### ESG Rating A

High performance on corporate governance, emissions and Clean Tech opportunities.



### Low ESG Risk

Demonstrating strong management of ESG relevant issues. Qualified in 2025 as **Industry ESG Top Rated**



### Member

Best score in governance, Human Rights, labor standards, and Climate Change

## Committed to talent



Recognized as a **Top Employer** for 8 years in a row for the outstanding commitment to talent and career development, ethics and sustainability.

## Acting on Climate Change



Net-Zero Target across the value chain by 2040 validated by SBTi.

- 2030: -90% scope 1 and 2 and -55% scope 3 emissions (intensity)
- 2040: -90% scope 1 and 2 and -97% scope 3 emissions (intensity)

# Main Figures 2017-2025

	FY17	FY18	FY19	FY20	FY21	FY22	FY23	FY24	FY25
<b>Backlog (€m)</b>	3,612	4,065	4,511	5,229	5,459	6,309	6,776	7,245	16,083
<b>Order Intake (€m)</b>	3,248	3,437	3,686	3,858	3,714	4,778	4,583	5,356	12,778
<b>Revenues (€m)</b>	3,011	3,104	3,204	3,043	3,390	3,851	4,343	4,843	5,457
<b>EBITDA (€m)</b>	266	293	343	230 <sup>(1)</sup>	349 <sup>(2)</sup>	400	446	545	636
<b>EBIT (€m)</b>	196	199	221	120 <sup>(1)</sup>	256 <sup>(2)</sup>	300	347	438	517
<b>EBIT margin</b>	6.5%	6.4%	6.9%	4.0% <sup>(1)</sup>	7.5% <sup>(2)</sup>	7.8%	8.0%	9.0%	9.5%
<b>Net profit Reported (€m)</b>	127	120	121	-65	143	172	206	278	436
<b>CAPEX (€m) net of subsidies</b>	40	79	76	39	-11	39	15	69	97
<b>FCF (€m)</b>	186	168	8	83	289	253	312	328	364
<b>Net Debt (€m)</b>	588	483	552	481	240	43	107	[86]	583

# Strategic Plan Leading The Future

---

# 2030 Vision | A&D global Group leveraging Advanced Digital Technologies



## Indra Land Vehicles

Progress in VCR & VAC<sup>1</sup> (TESS Defence)

Exploring further M&A to enhance and strengthen our capabilities

## Indra Electronic Defence

Cutting-edge portfolio including Radar, Sensors, Electronic Warfare, Command, Control – C4i

## Indra Weapons & Ammunition

Enhancing our competitive position through UAVs, C-UAS<sup>2</sup>, Loitering Munition and Missiles

Alliances/ M&A as enabler

## Indra Military Space

Key provider of secure communications, Earth and Space surveillance, positioning for military

## Indra Civil Space

End-to-end secure communications, next-gen services, SSA & SST<sup>3</sup> for governments and commercial customers

## Indra Air Traffic Management

Boosting digital capabilities and air surveillance

Strengthening footprint in USA

## Indra Mobility

Transforming the sector through digital offering: intelligent transport systems, multimodal solutions and connected vehicle

## IndraMind

Artificial Intelligence for superiority in multidomain operations

Artificial Intelligence for automation of critical operations

## Minsait

Evolving towards high value digital services and solutions

1. Combat Vehicle on Wheels & Army's Chain Support Vehicle; 2. Counter-Unmanned Aerial Systems; 3. Space Situational Awareness & Space Surveillance and Tracking

# We are successfully implementing the strategic lines of the Strategic Plan *Leading the Future: Focus*

## Business strategic lines

1. Aerospace & Defence



Industrial Plan



2. Space NewCo



3. Technology



Tech Operations

## Cross-Group strategic lines

4. Strengthen presence in new 'home markets'

5. Activate portfolio rotation and expand the ecosystem

6. Increase investment in technological R&D

7. 'Double down' on critical talent

# Indra Group continues its roadmap to become a leading player in Europe

## Spain

Spain Defense Investment  
2025 [€bn]

c. 33.0



Investment in Special  
Modernization Programs  
[€bn]<sup>1</sup>

c. 24.8



Special Modernization  
Programs awarded to  
**Indra Group**<sup>1,2</sup> [€bn]

 **INDRA**  
GROUP

c. 13.8

## NATO



**5% GDP**

*in Defense and  
Security by 2035*



>4.7% current investment



>3.5% starting in 2029



>2.5% starting in 2027

# 1. Indra Group Defence Vision

## 8 Main Programmes from 24-26 Strategic Plan

### FCAS

National Coordinator for NGWS programme, & international leader for the Sensors pillar

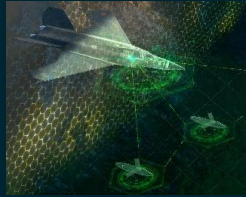

### Eurofighter

Supply of next-generation Radar & Electronic Defence Systems



### NH-90

Integration of Self-protection & Simulation Systems



### A-400M

Supply of Surveillance & Self-Protection Systems



### MKIII (Tiger)

Modernization of Tiger helicopters with Mission & Electronic Defence Systems



### Chinook

Supply of Mission & Electronic Defence Systems



### VCR 8x8

Integration of Mission & Situational Awareness Systems in ~350 vehicles



### F110

Integration of Electronic Defence Systems & next-generation Sensors



## PEM

### Products to be delivered under 2025 Special Modernization Programs (PEMs)



Land vehicles



Radios

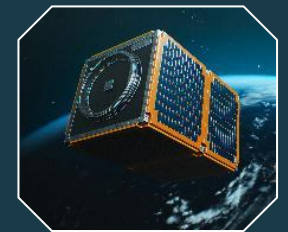

Satellites

Non exhaustive



C-UAS



Drones



Cyber defense

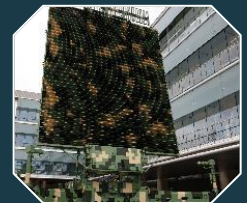

Radars

# 1. New 2025 PEM programs reinforce Indra pivotal role in the Spanish Defence industry

## Government-approved<sup>1</sup> pre-financing lines

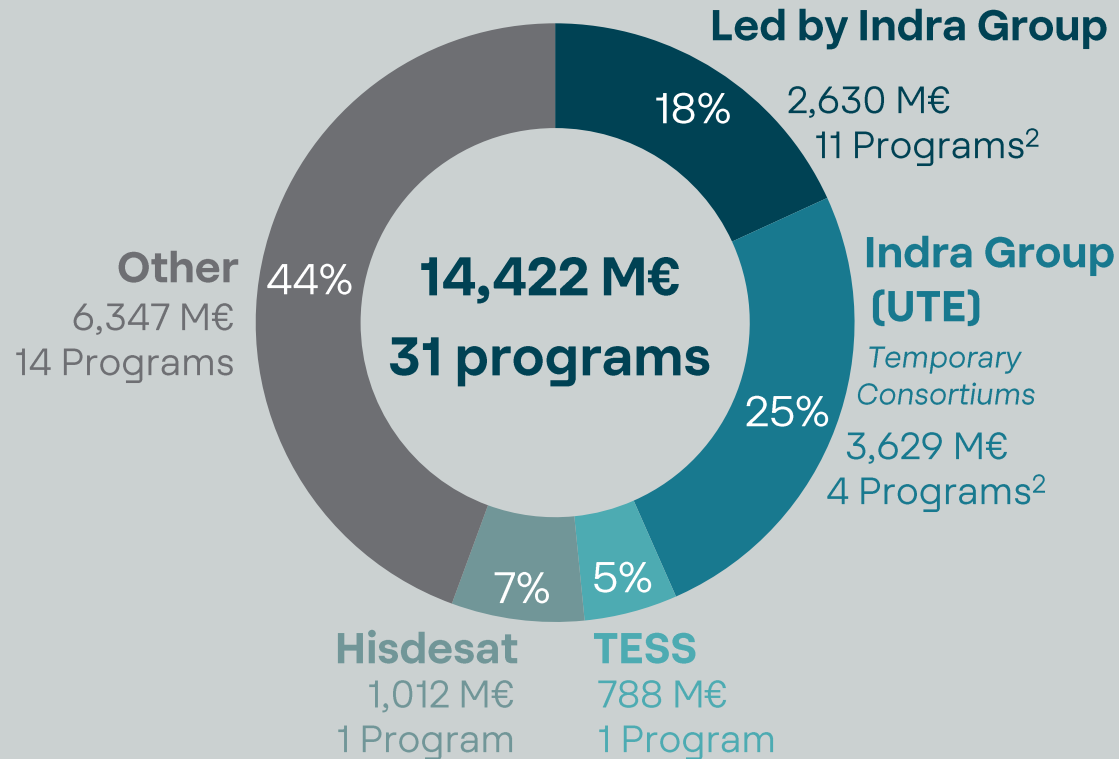

**17 programs out of 31** led by Indra or Temporary Consortiums involving Indra – Additionally, Indra is positioned to take part in **12 additional** programs as subcontractor

## Programs contract size

New Generation Weapon System (NGWS) <sup>2</sup> – 540 M€
Counter-Battery Radars (RADAR – FI) – 25 M€
Classified Cyber Range (CYBER-RANGE) – 58 M€
Anti-Aircraft Artillery Operations Center System (COAAAS) – 1,687 M€
Joint Tactical Radio System (SCRT) – 1,174 M€
Wheeled Bridge-Laying Vehicle (VLP) – 316 M€
Comprehensive Advanced Cybersecurity System (SCOMCE) – 132 M€
Main Ground Combat System (MGCS) – 37 M€
Shipborne Launcher System (SLE) – 51 M€
Robotic Aerial Technologies for Sensorized Autonomous Mobility – 364 M€
Replacement of Legacy Systems in Electromagnetic Spectrum (REE-EW) – 308 M€

National Future Combat Air System (FCAS) <sup>2</sup> – 160 M€
Counter Unmanned Aerial Systems (C-UAS) – 37 M€
Modernization of Command, Control & Communications Systems – 785 M€
Comprehensive Efficient Amphibious Projection System (VACIM) – 306 M€
Self-Propelled Howitzers (ATP) – 6,736 M€
Replacement of Legacy Systems in Electromagnetic Spectrum (REE-SCAPA) <sup>3</sup> – 16 M€

Tracked Support Vehicle (VAC) - ND

PAZ II Satellite Program – 1,090 M€

## 2. Indra Group Air Traffic Management Vision

---

Maintain **leadership** in Air Traffic Management in **Europe, Middle East and Latin America**

Reach the **number one position globally** by strengthening our core presence in **North America and Asia-Pacific**

Extend the **automation technological solution** to Middle East, Latin America and Asia



## 2. Indra will expand its European ATM leadership to other regions & market segments



Europe

### European leadership consolidation

- Reinforce iTEC alliance, pushing forward new automation solutions
- Capture surveillance system renewal programmes



North America

### Expansion of leadership to North America and Asia-Pacific/India

- Integration of acquisitions *[e.g. SELEX]* and scale-up with alliances & bolt-ons to strengthen positioning towards incoming U.S. programmes
- Capture large system renewal opportunities and develop Single Sky programmes and technology-partner-like alliances in Asia-Pacific



Asia-Pacific



UTM

### Development of local unmanned traffic management platform and opportunities

*[e.g. U-Space Service Provider]*

# 3. Indra Group Space Vision

---

Tier-1 European referent with global footprint and leadership in main European programs

End-to-end capabilities along the value chain, with increasing focus on MEO/LEO initiatives

Dual civil-military offering for satellite secure communications, observation and navigation



# 3. Hispasat & Hisdesat acquisition | Integrated positioning across the value chain to deliver end-to-end Space missions

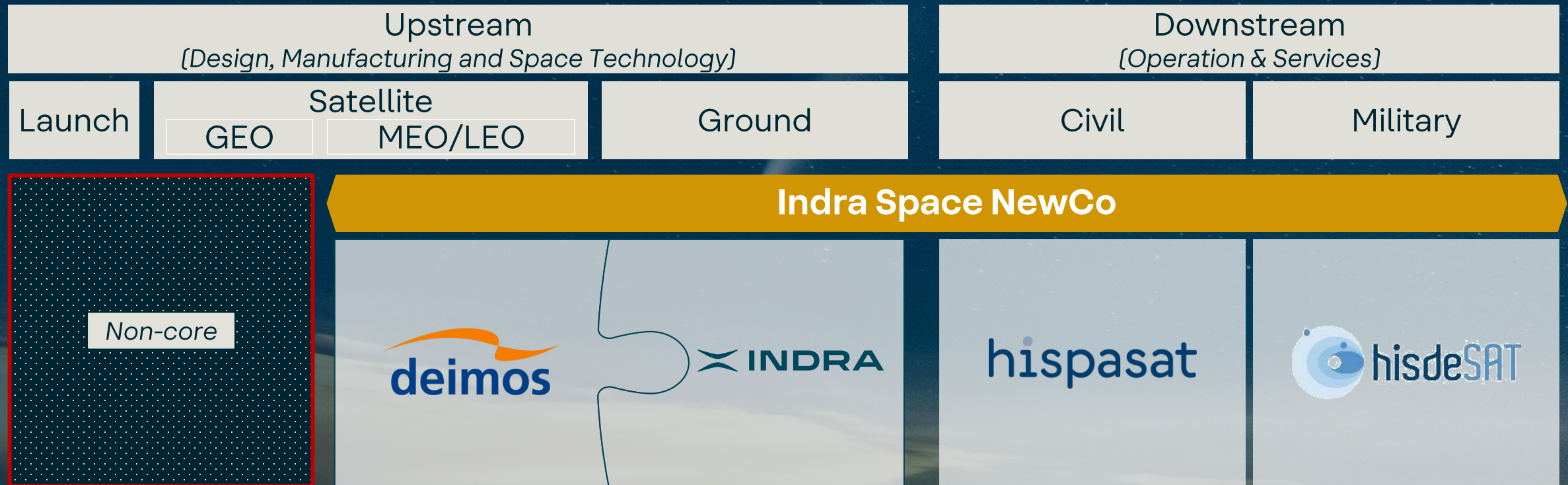

# 3. Indra Group has created Indra Space, its Space unit as committed in 2024

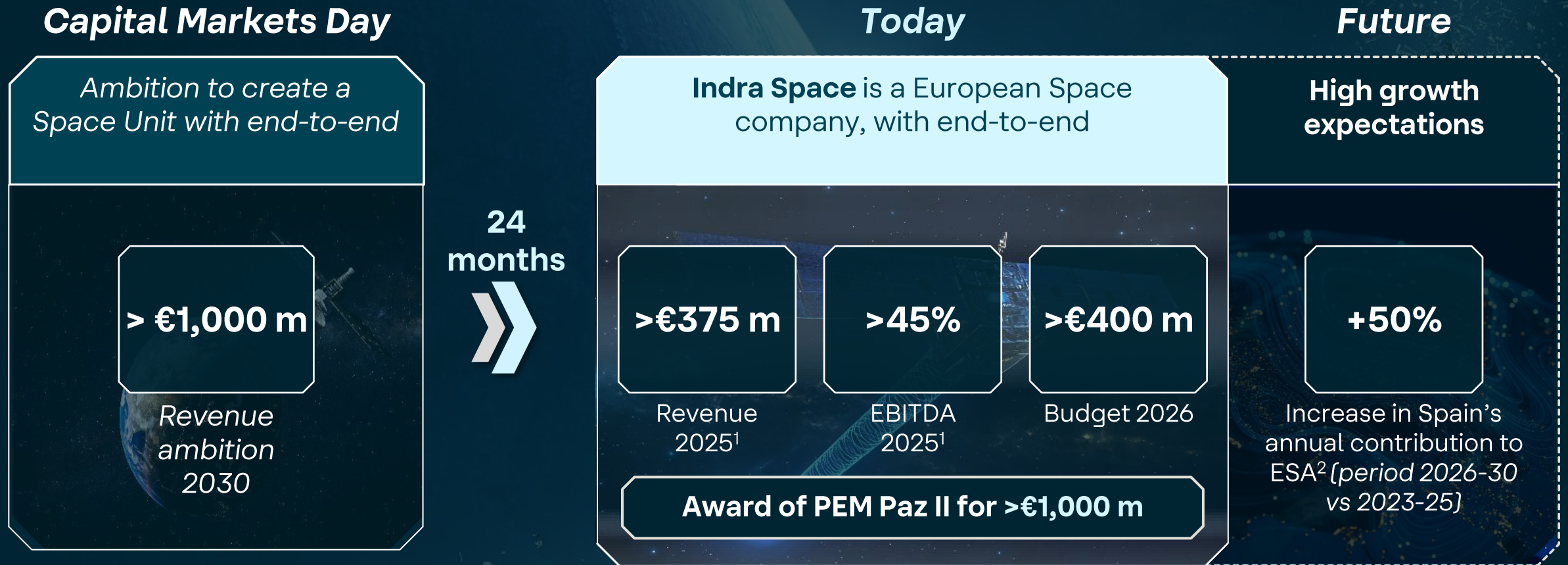

# 4. Indra Group Minsait Vision

---

Become one of the **main European and Latin American IT Services players**

Aggressively rebalance portfolio towards most-advanced **digital business** lines

Accelerate expansion into **higher-value geographies**



# 4. AI advances are being leveraged to increase internal productivity and enhance product sophistication

## AI in internal productive processes and corporate functions

Operations Tech

>10%

Revenue per employee in SW development

61%

Advanced use of AI in software development

Industrial Operations



Integration of AI in production plants

>10

Partnerships with hyperscalers and strategic partners

## Enhancing the sophistication of Indra Group

> AI-based solutions to support our clients' decision-making

*e.g. Predictive AI in insurers (loss-adjustment assessments), virtual assistants in airlines, detection of defective parts in assembly lines*

> 6 use cases of IndraMind prioritized

Sovereign intelligence

Emergency Management

Drone swarms

Cyber Defense

Protection of Critical Infrastructure

Protection of sovereignty

> Evolution of the **Command and Control**

The **cross-cutting implementation of Tech Operations** has enabled the deployment of AI across the entire Indra Group

# 4. We have made progress in the evolution of Minsait

**Evolution toward a portfolio of high-value solutions**

- Decisive actions in the second half of the year
  - Divestment of **BPO**, non-core for Indra Group
  - **Reorganization** of **sales teams** (detailed account plans)
  - Commercial focus on **high-value solutions** (double-digit growth in Data, Cloud)

**Cross-functional deployment of digital capabilities to serve all Indra Group Business Units**

- **Operations Tech (+31,000 people):**
  - Technological evolution of the offering across all Indra Group businesses (e.g. Mobility)
  - Support for the award and delivery of Indra Group technology projects (e.g. Defense)
- Support in the **digitization** of Indra Group:
  - Supply chain (e.g., sensorization of production plants)
  - Corporate functions (e.g., finance)

Achieving an increase of **9.7%** in **revenue per employee**

# IndraMind

"Delivering **advanced software & AI-driven solutions** that empower sophisticated **decision-making** and ensure reliability of **mission-critical operations**"

01

Build a **sovereign, advanced AI native platform**

02

Develop **customer-centric use cases** to cover needs from Spanish & European institutions and private companies

03

Bring together **advanced capabilities** (Data, Cyber...) to develop **cutting-edge tech**

# 4. IndraMind: Offering that covers all trends and all domains in both civil and military fields...

Trends in protection solutions

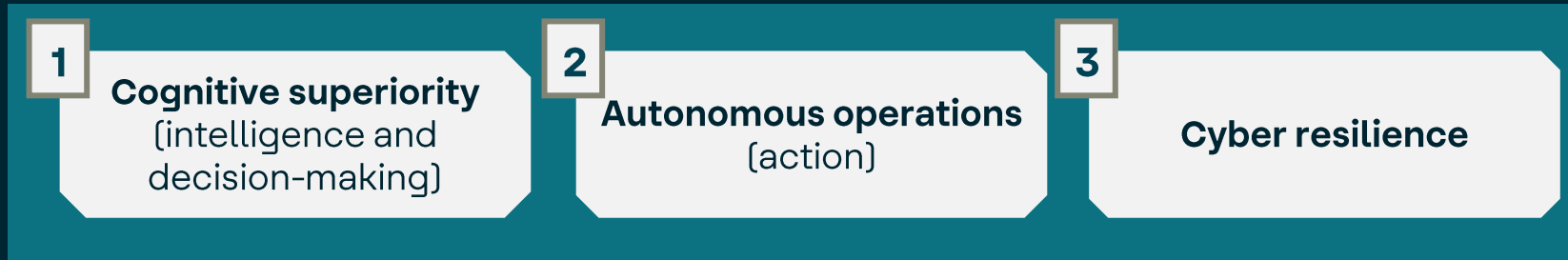

All domains



# 4. IndraMind aims to reach €1,000M+ revenue by 2030 to become a leader in Europe

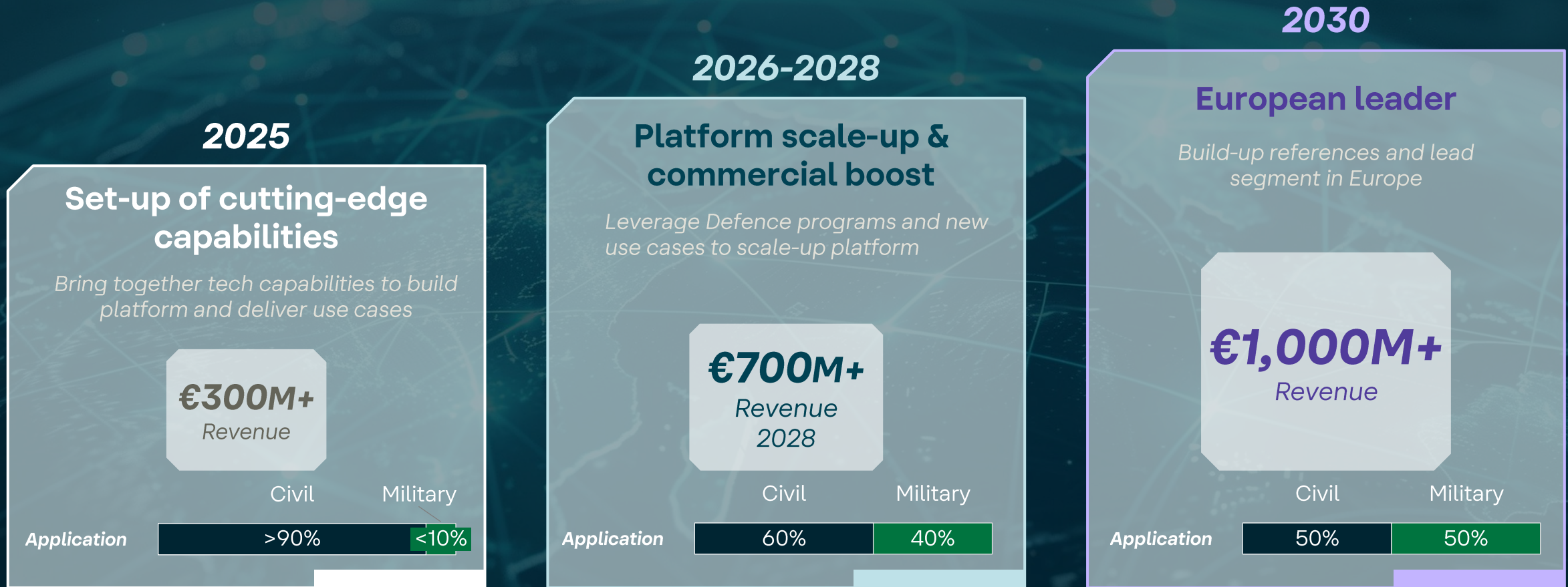

Expected growth: **25–30% CAGR**<sub>25-30</sub>

# 5. The international business has been reviewed and simplified, facilitating international expansion

## Reorganization of priority markets

Simplification from 27 to 19 organizational units

### Europe (6)

- United Kingdom & Ireland
- Germany
- Norway
- Italy
- Poland
- Brussels & EU

### Middle East (3)

- Saudi Arabia
- U.A.E. & PULSE (JV EDGE)
- Rest of Middle East

### North America (2)

- U.S.
- Canada

### LatAm (4)

- Peru and Southern Cone
- Col., & C.A and the Caribbean
- Brazil
- Mexico

### Other commercial geographies (4)

## Main international contracts in 2025

Not exhaustive

### North America

- Modernization of the FAA radar network in the U.S.
- Canada's NAV air simulators

### Europe

- Ticketing TfL in the UK
- Space surveillance radars in Germany
- Ticketing public transport in Ireland
- Modernization of air traffic in the UK
- Modernization of air traffic in Belgium

### Middle East

- Contract renewal ticketing for Haramain
- Radars in Oman
- Control towers at Abu Dhabi

### LatAm

- Rail communications system in Chile
- Tolling systems and ITS<sup>1</sup> in Colombia
- Digital services for a bank in Brazil

### Africa

- Maintenance of the Cairo metro
- Radars in Libya

### Oceania

- Safe aviation radars in New Zealand

# 6. Ecosystem expansion

## 2025 M&A activity

The infographic is divided into three main sections:

- Acquisitions:** This section lists several companies with their logos and small circular icons indicating their origin. The companies include hispasat, hisdeSAT, Clue, AERTEC (Defence and Aerial Systems), WAKE, FYLA (WE LASER THE NEW INDUSTRY), TESS (DEFENCE), and GUARDIANUTM (OPERATING SYSTEM).
- 100+ Alliances and agreements:** This section is labeled "Non-exhaustive" and lists a wide range of partners. The companies shown are LEONARDO, PULSE, ARQUIMEA, saes (Innovar, Desarrollar, Proteger), ELTGROUP, AIRTIFICIAL, LeciTrailer, MULTIVERSE (COMPUTING), CALIDUS (خالدس), FICOSA, BSC, and piedrafita.
- Divestments:** This section features the logo for BPO and the text "+ Other divestments under analysis".

Indra Group continues evaluating M&A opportunities to complete its capabilities

# 6. Indra Group continues to strengthen investment in R&D

## Investment in R&D

€472 m

Investment in R&D 2025<sup>1</sup>

€83 m

CapEx in engineering

8.7%

% of Revenue allocated to R&D

## Priority technologies



Cyberdefense



Gallium Nitride



Photonics

Quantum

Applied AI

## Collaborating with top-tier partners

400+ agreements with universities and vocational training centers



Advanced microelectronics design



Quantum research and cryptography



AI research and Computer vision



Space tech. development with Big Data and AI

# 6. 4x increase in Indra Group's industrial footprint by 2027



1. It considers the jobs and the investment associated with the expansion of the footprint of production and of engineering

# 6. Indra Group has transformed its industrial DNA in 2025 to secure deliveries from 2026 onwards



**Expansion  
of the footprint**

**x4**

**industrial  
footprint** of Indra  
Group 2027 vs.  
2024



**Increase in production**

**x2.5**

**production** 2026 vs. 2024

- Product standardization
- Serial production
- Increase from 2 to 3 shifts in key products



**Tiering of the supply  
chain**

**450**

**Suppliers Tier 1 strategic**

**Excellence and full focus on industrial management**

- Implementation of an industrial management mindset
- Deployment of a real-time digital platform for production and delivery tracking

# 6. We are making progress in the standardization and industrialization of our products



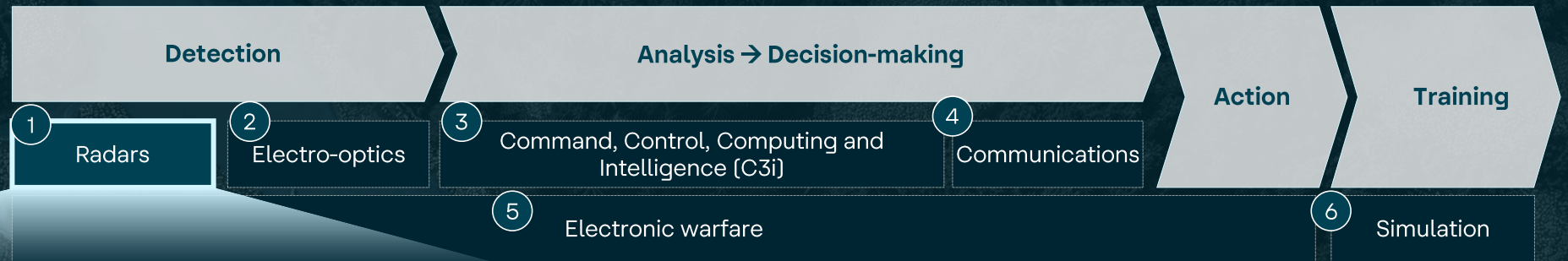



Capital Markets 2024:  
"Focus on **6 technology categories** to develop 11 integrated solutions"



## 4 objectives set in the CMD 2024

<b>x3</b>	Annual units in production
<b>+60%</b>	Common elements across markets for the main radar families
<b>13</b>	Radar families in 2030 vs. 18 in 2025
<b>50%</b>	Reduction in production lead time

## Progress made in priority radars

<b>x4</b> ✓	In annual units produced	 LTR25  Nemus
<b>+80%</b> ✓	Common elements in the AESA radar family	 MTR  Nemus
<b>14</b> ✓	Radar families in 2026 On track to reach the 2030 target	
<b>50%</b> ✓	Reduction in lead time with increased shifts and process optimization	 LTR25  Nemus

# 6. Indra Group has worked on tiering its supply chain

## Supply chain driving role

78%



Defense procurement from Spanish suppliers

+70%

Increase in procurement spend volume vs. 2024, increasing +80% the average contracting per supplier

<450

Strategic Tier 1 suppliers that concentrate 90% of the spend in procurement the group's A&D

## Cost reduction

Cost savings in procurement of key products

>10%



Nemus



PSR2D



PSR3D



LTR25

Forecast to double the savings with the consolidation of serial production

# 7. Indra is a reference in talent and we have increased both revenue and EBITDA per employee

## Revenue per employee (€k)

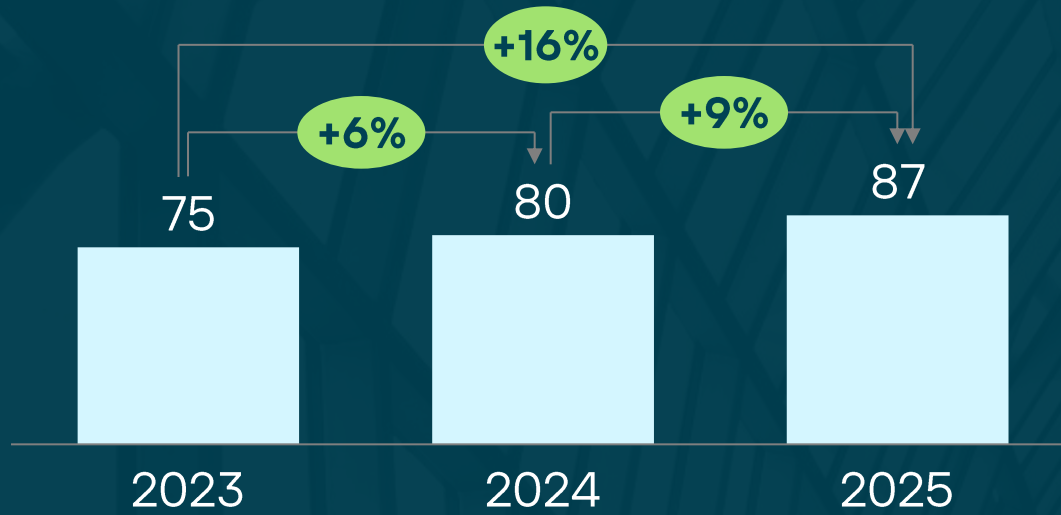

EBITDA/employee (€k)

7.7

9.0

[+16% vs '23]

10.2

[+13% vs '24]

# Employees (k)

57.8

60.6

62.4

## Indra Group is a reference in high-value talent

- **>2,400 jobs** in technology created in 2025
  - In line with the objective to create >5,000 high-value technology and digital jobs by 2026
- **3% workforce growth** vs 2024
  - 36% workforce growth in Defense in 2025
- Recognition as **Top Employer** for the 8th consecutive year
- Recognition by S&P as one of the **three most sustainable companies worldwide**
  - the only European company in the top 10

# Financial projections

---

# Leading The Future



2023

2026

2030

<b>Revenues</b>	€4.3B	€6B	€10B
<b>EBITDA</b>	10.3%	>12%	>14%
<b>EBIT</b>	8.0%	10%	12%

€0.9 B  
cumulative '24-'26

€2-2.5 B  
cumulative '27-'30



**>€3 B**  
**'24-'30**

# Indra Group has consistently exceeded its targets since 2023

	Starting point	Strategic Plan Leading the Future: Focus				
	2023 Result	2024 Guidance	2024 Result	2025 Guidance <sup>1</sup>	2025 Result <sup>2</sup>	2026 LtF Target <sup>3</sup>
Revenue [€m]	<b>4,343</b>	<b>4,650</b>	<b>4,843</b> ✓	<b>5,200</b>	<b>5,457</b> ✓	<b>&gt;6,000</b>
EBIT [€m]	<b>347</b> [8.0%]	<b>400</b> [8.6%]	<b>438</b> ✓ [9.0%]	<b>490</b> [9.4%]	<b>517</b> ✓ [9.5%]	<b>&gt;600</b> [10%]
FCF [€m]	<b>312</b>	<b>250</b>	<b>328</b> ✓	<b>300</b>	<b>364</b> ✓	<b>900</b> [cumulative '24-'26]

# We are increasing our ambition for the 2026 Guidance

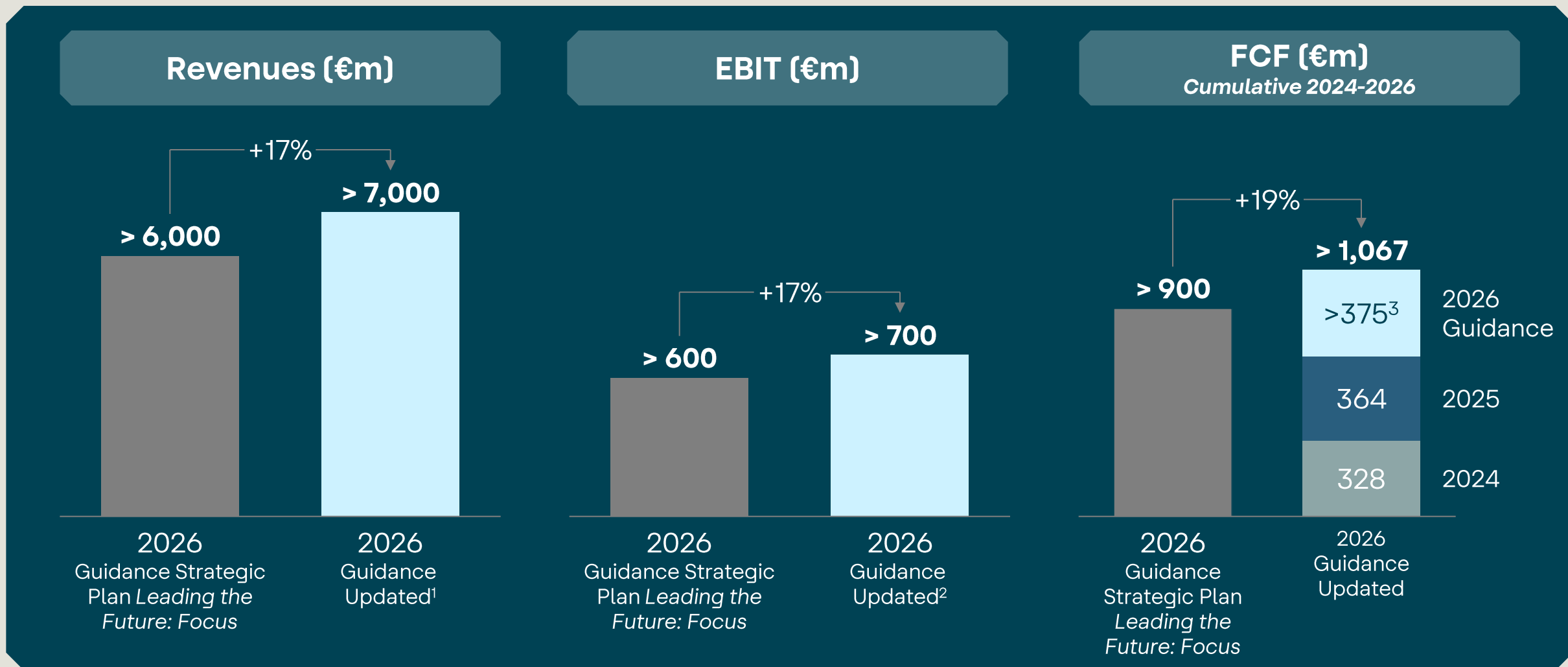

# Capital Allocation Priorities



## M&A Acceleration

Allocate >75% of acquisitions spend on Defence & Aerospace

Focus of M&A targets in Spain, Western Europe, Middle East & North America

M&A transactions will be aligned with strategy and growth story, **and** accretive for shareholders

---



## Continued increase in technology investment

+€1.2 B technology spending until 2026

- ~€0.7 B programme-funded R&D spending
  - ~€0.4 B other R&D spending
  - ~€0.1 B Indra Technology Hub
- 



## Financial stability & greater shareholder returns

2026 Net Financial Debt / EBITDA of 1.0x – below industry peers – with a maximum threshold of up to 2.0x in '24-'26 period

Dividend practice in line with current payout ratios [~20%], consistent with company strategy



# Anex I: Last Quarterly Results

---

# 1Q26 Indra Group Main Highlights



- Change in Group Chairmanship – appointment of Ángel Simón
- Portfolio rotation: Closing of BPO divestiture; ongoing M&A pipeline of >20 deals
- +3% increase in workforce vs 1Q25, boosted by growth in Defence (+35%)

## Defence

- Transfer of PEM pre-financing to suppliers: 23 new agreements signed
- Expansion of industrial footprint in Spain: opening of León and Córdoba plants expected for 3Q26
- TESS consolidation and delivery model improvement – deliveries on track
- Signing of international agreements: Hanwha, Rheinmetall, Diehl, ELT

## Space

- Consolidation of Hispasat and Hisdesat into Indra Group
- Progress in the design of ground segment for IRIS2 – promising outlook, with upcoming review on April 30th rendez-vous
- Launched industrialisation plan for mid-sized (300kg) satellites

## Air Traffic

- Inauguration of Kansas plant – fully operational by 4Q26
- Securing of key international contracts:
  - FAA radar modernisation, USA

## Mobility

- Securing of key international contracts:
  - TFL ticketing, UK
  - Mecca-Medina railway renewal, Saudi Arabia
  - Railway modernisation, Chile

## IndraMind

- Deployment of "IndraMind AI sovereign platform"
- Acceleration of products & use cases leveraging our vertical/ sector know-how

## Minsait

- Divestiture of non-core units
- Progress in transversal deployment of technological capabilities: 1.300 developers working across A&D projects
- Optimization of international footprint (e.g. LatAm)
- Creation of "AI Accelerator" to catalyze group-wide AI transformation

## Indra Group reaffirms its 2026 financial guidance



>€7.0bn  
Revenue

>€700m  
EBIT

>€375m  
FCF

# Tailwinds for Indra Space, operating already as an integrated player

## Indra Space operating as an integrated player



Upstream

Downstream



## Growing institutional investment in Space



32%

Increase in ESA budgets for the '26-'28 cycle<sup>2</sup>

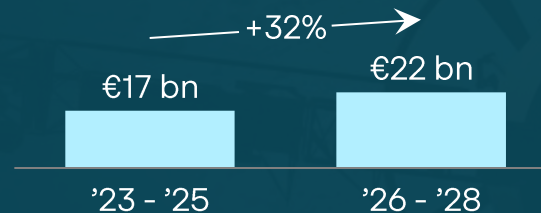

€625 m

Investment approved through the AEE<sup>3</sup>

## IRIS<sup>2</sup> is a reality, outlook is promising

IRIS<sup>2</sup> project is a reality – Indra already developing its roadmap

Outlook is promising for the project and Indra participation – upcoming review on April 30<sup>th</sup> rendez-vous

## Satellite component industrialisation plan launched

Industrialisation plan for low and mid sized satellites (60-300kg) already launched

2Q26  
Final design of new production line

4Q26  
Construction of pilot line

1. Includes Space capabilities from Indra's businesses (Defence, Air Traffic, Mobility & Minsait) and capabilities gained through the acquisition of Deimos  
2. Triennial budget. 3. AEE (Spanish Space Agency) budget allocated across 4 programs (ESCA+, LEO-PNT, IRIS2, Rocket Launchers)

# Indra Group Technology roadmap | Minsait, IndraMind and Tech Operations

## Indra Group with unique positioning to take advantage of AI disruption

**1** **Divestiture of non-core units: human capital intensive and non-AI resilient BUs and geographies**

- Reduction of 5,000 technicians through BPO divestment

**2** **Transversal utilization of tech capabilities beyond Minsait (BUs and Geographies)**

- 1,300 developers staffed beyond Minsait (Defence, Mobility...)

**3** **Optimization of international footprint**

- OneLatAm Plan objective: reduction of 2,000 technicians

**4** **"IndraMind AI sovereign platform" up and running with use cases**

- Already deployed in +5 clients [confidential references]
- Strong '26-'28 pipeline

**5** **Group-wide AI transformation**

- **AI for clients:** AI by design in all solutions
- **AI for Indra business processes** (e.g., SW development, supply chain)
- **AI for Indra corporate processes:** (e.g., legal)

**6** **Acceleration of products & use cases leveraging our vertical/sector know-how**

- Tech products in Payments (e.g. Nuek), Healthcare...
- Vertical use cases in civil and military (e.g., emergency management)

Indra Group's Tech roadmap will be presented in Leading the Future Scale-up Strategic Plan

# 1Q26 Group Financial Results Headlines

## Backlog<sup>1</sup>

€20,334m

+154.1%

## Order Intake

€2,856m

+55.8%

## Revenues

€1,334m

+14.6%

## EBITDA Margin

14.5%<sub>(€194m +54.7% YoY)</sub>

+3.8pp

## Operating Margin<sup>2</sup>

9.7%<sub>(€129m +20.3% YoY)</sub>

+0.5pp

## EBIT Margin

8.9%<sub>(€118m +24.2% YoY)</sub>

+0.7pp

## Net Income

€76m

+28.4%

## Free Cash Flow<sup>3</sup>

€1,444m

+1,764.8%

## Net Debt<sup>3</sup>

€-855m

-1.3x Net Debt/EBITDA LTM

1. Includes €2,704m from Hispasat & Hisdesat; 2. EBIT before Other Operating Income & Expenses, including: staff reorganization, impairments, capital gains, integration and acquisition costs, fines, amortization of intangible assets (PPA from acquisitions) and equity-based compensation; 3. Includes prepayments received from the Special Modernization Programs (PEMs)

## 1Q26 performance in line with annual targets

- Backlog reached €20.3bn with an Order Intake figure of €2.9bn [+56% vs 1Q25]
- 1Q26 Revenues up +15% with all divisions recording YoY growth, standing out Defence and ATM
- EBITDA and EBIT increased +55% and +24% YoY respectively, while Indra Group's profitability improved 0.7pp, reaching an EBIT margin of 8.9%
- Net income amounted to €76m, up +28% vs 1Q25, while FCF stood at €1.4bn in 1Q26 vs €77m in 1Q25

# Sales Growth in 1Q26

## 1Q26 Revenues

Reported	+ 15%
Local Currency	+ 15%
Organic	+ 6%



## 1Q26 Revenues breakdown by Geography

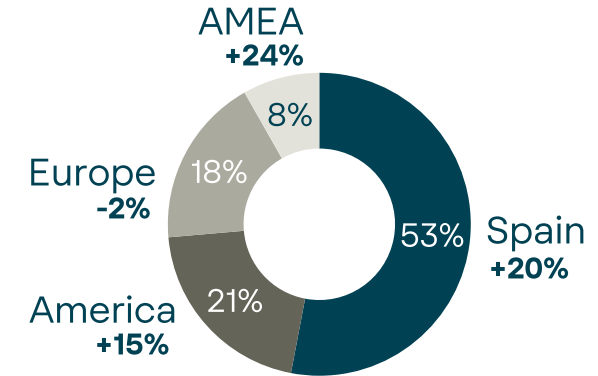

International Business covering 49%

## 1Q26 EBIT breakdown by Division

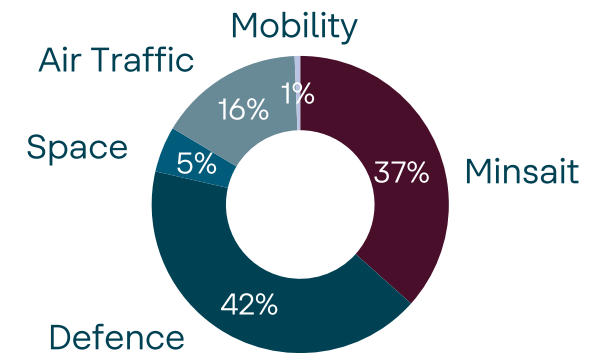

Defence, Space and ATM EBIT account for 63% of total

# Group Workforce Evolution<sup>1</sup>

Revenue LTM/Employee

**+3%**

vs Dec 25

**+11%**

vs Mar 25

**>15%**

vs Mar '25  
*Considering divestitures*

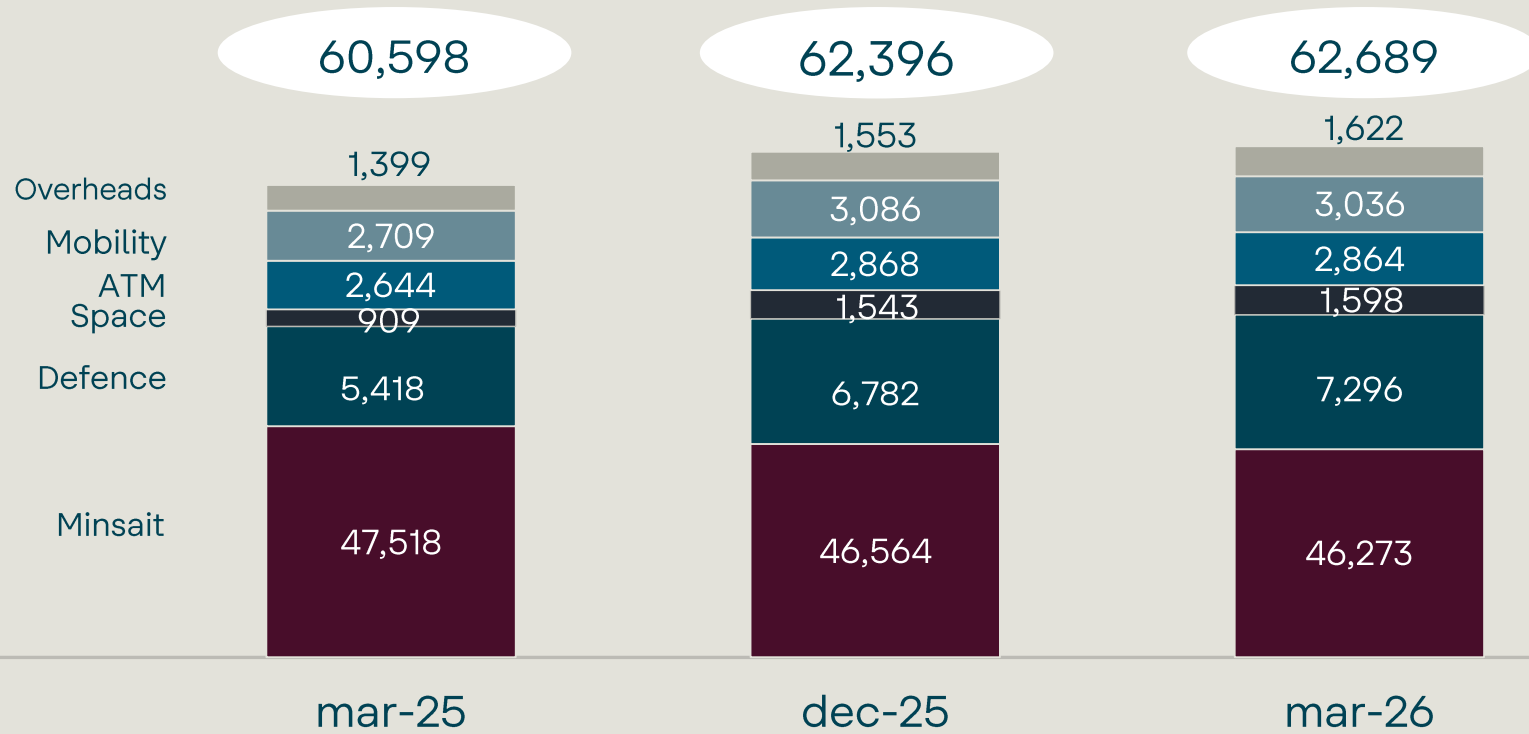

**+3% increased workforce vs 1Q25, boosted by Defence (+35%)**

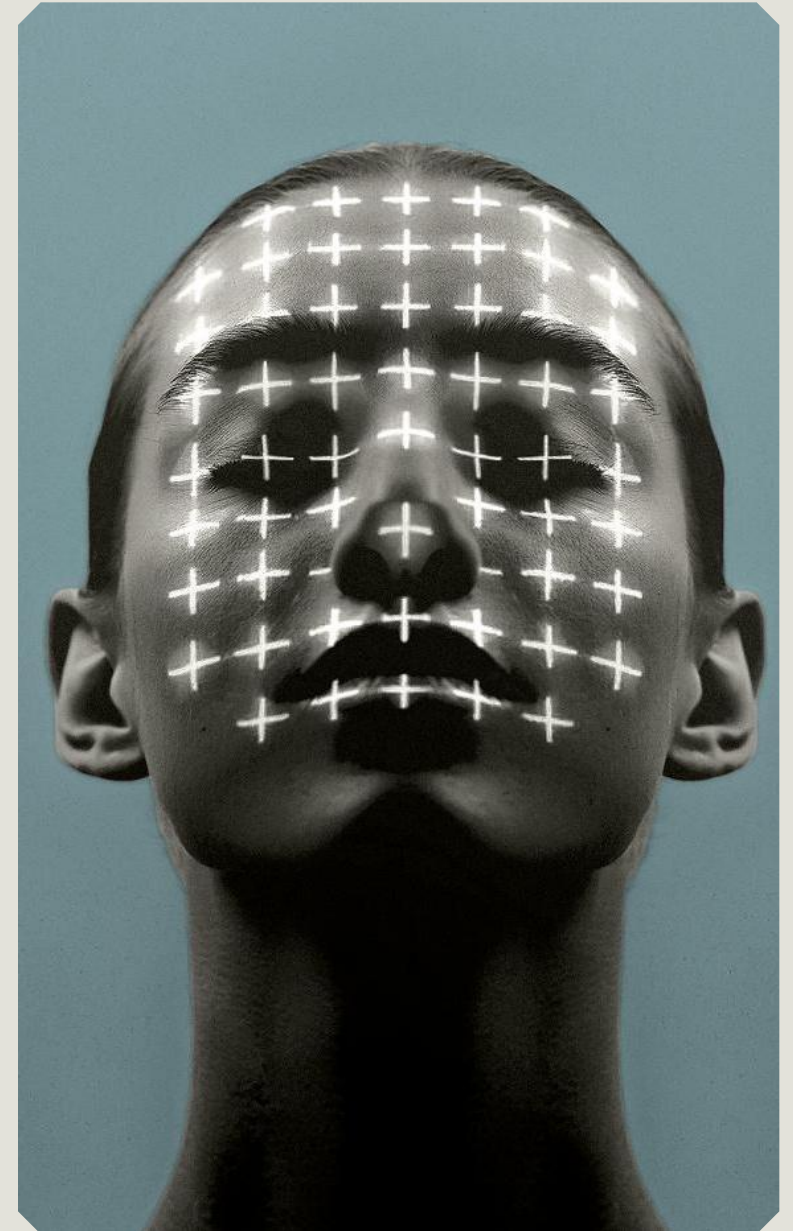

# Indra Defence 1Q26

## Backlog

€11,402m

+279.0%

## Order Intake

€493m

+42.8%

## Revenues

€275m

+32.5%

## EBITDA Margin

25.7%<sub>(€71m +64.8% YoY)</sub>

+5.0pp

## Operating Margin<sup>1</sup>

18.6%<sub>(€51m +36.4% YoY)</sub>

+0.6pp

## EBIT Margin

18.1%<sub>(€50m+35.6% YoY)</sub>

+0.4pp

## Book-to-Bill

1.80x

1.67x in 1Q25

## Backlog/Revs LTM

8.29x

3.01x in 1Q25

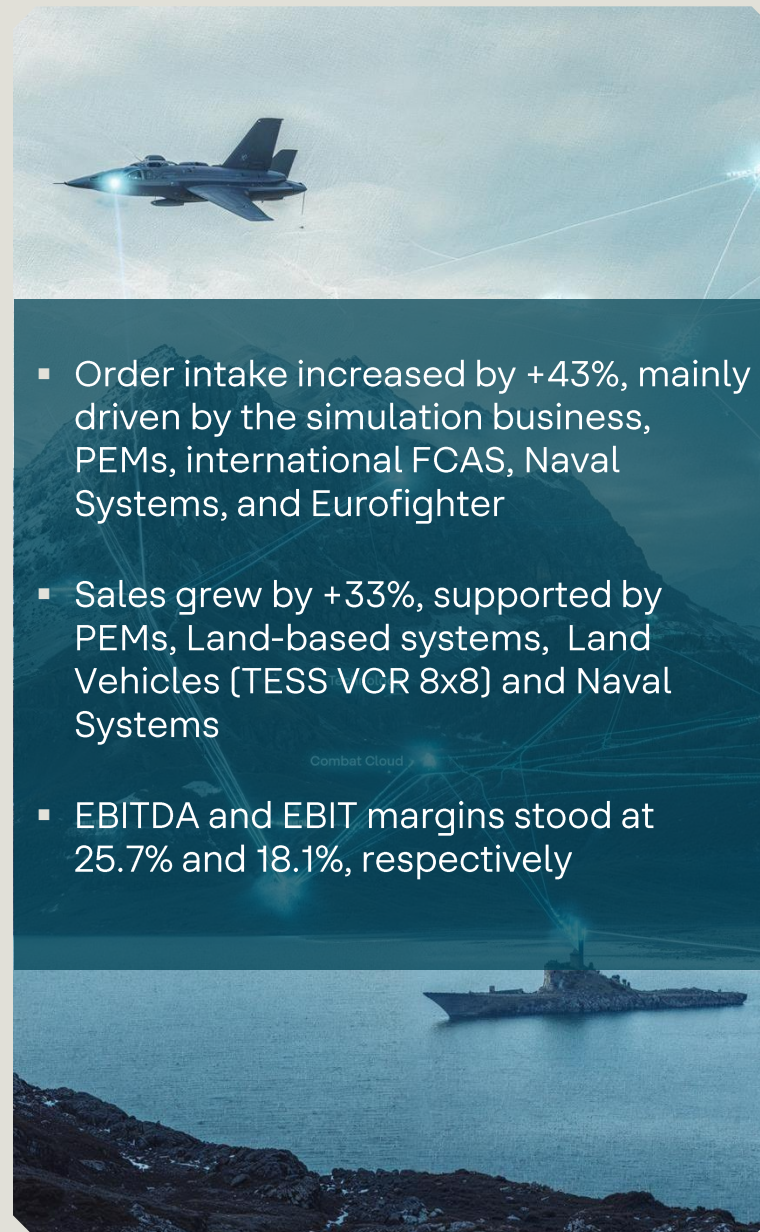

- Order intake increased by +43%, mainly driven by the simulation business, PEMs, international FCAS, Naval Systems, and Eurofighter
- Sales grew by +33%, supported by PEMs, Land-based systems, Land Vehicles (TESS VCR 8x8) and Naval Systems
- EBITDA and EBIT margins stood at 25.7% and 18.1%, respectively

1. EBIT before Other Operating Income & Expenses, including: staff reorganization, impairments, capital gains, integration and acquisition costs, fines, amortization of intangible assets (PPA from acquisitions) and equity-based compensation.

# Indra Space 1Q26

## Backlog<sup>1</sup>

€2,868m

+1,349.9%

## Order Intake

€56m

+87.2%

## Revenues

€89m

+393.0%

## EBITDA Margin

38.8%<sub>(€35m; €-1m in 1Q25)</sub>

+46.8pp

## Operating Margin<sup>2</sup>

7.0%<sub>(€6m; €-2m in 1Q25)</sub>

+17.8pp

## EBIT Margin

6.6%<sub>(€6m; €-2m in 1Q25)</sub>

+17.6pp

## Book-to-Bill

0.63x

1.66x in 1Q25

## Backlog/Revs LTM

16.92x

3.05x in 1Q25

1. Includes €2,704m from Hispasat & Hisdesat; 2. EBIT before Other Operating Income & Expenses, including staff reorganization, impairments, capital gains, integration and acquisition costs, fines, amortization of intangible assets (PPA from acquisitions) and equity-based compensation;

- Backlog reached €2.9bn, driven by the consolidation of Hispasat and Hisdesat
- Order intake increased by +87%, mainly driven by America, Hispasat services in Peru, and Hisdesat
- Revenues grew by +393% due to the inorganic contribution of Hispasat and Hisdesat
- Margin improvement due to the consolidation of Hispasat and Hisdesat: EBITDA margin of 38.8% (vs -8.0% in 1Q25) and EBIT margin of 6.6% (vs -11.0% in 1T25)

# Indra Air Traffic 1Q26

## Backlog

€1,135m

+8.8%

## Order Intake

€431m

+47.2%

## Revenues

€138m

+17.2%

## EBITDA Margin

16.8%<sub>(€23m 21.4% YoY)</sub>

+0.6pp

## Operating Margin<sup>1</sup>

13.7%<sub>(€19m 19.8% YoY)</sub>

+0.3pp

## EBIT Margin

13.5%<sub>(€19m +20.6% YoY)</sub>

+0.3pp

## Book-to-Bill

3.12x

2.48x in 1Q25

## Backlog/Revs LTM

2.09x

2.22x in 1Q25

1. EBIT before Other Operating Income & Expenses, including staff reorganization, impairments, capital gains, integration and acquisition costs, fines, amortization of intangible assets (PPA from acquisitions) and equity-based compensation;

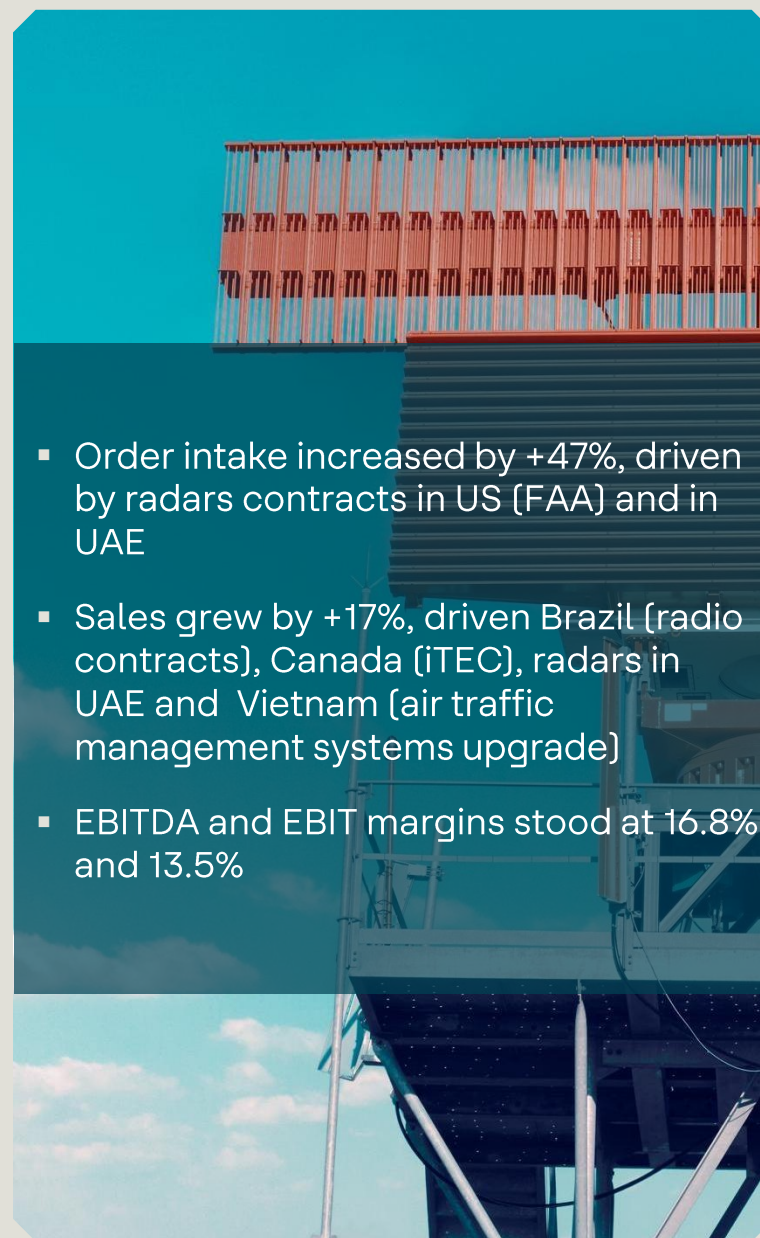

- Order intake increased by +47%, driven by radars contracts in US (FAA) and in UAE
- Sales grew by +17%, driven Brazil (radio contracts), Canada (iTEC), radars in UAE and Vietnam (air traffic management systems upgrade)
- EBITDA and EBIT margins stood at 16.8% and 13.5%

# Indra Mobility 1Q26

## Backlog

€1,714m

+67.0%

## Order Intake

€768m

+421.7%

## Revenues

€80m

+1.2%

## EBITDA Margin

4.7% (€4m -31.7% YoY)

-2.3pp

## Operating Margin<sup>1</sup>

1.4% (€1m -70.0% YoY)

-3.5pp

## EBIT Margin

0.9% (€1m -78.4% YoY)

-3.3pp

## Book-to-Bill

9.59x

1.86x in 1Q25

## Backlog/Revs LTM

4.30x

2.84x in 1Q25

1. EBIT before Other Operating Income & Expenses, including staff reorganization, impairments, capital gains, integration and acquisition costs, fines, amortization of intangible assets (PPA from acquisitions) and equity-based compensation;



- Order intake increased by +422%, driven by Transport for London in UK and the railway systems maintenance contract in Saudi Arabia
- Sales increased by +1%, with strong contribution of toll systems in the US and the ticketing and intelligent transport systems in Spain, partially offset by declines in Europe (ticketing in Ireland) and AMEA (rail transport network in Saudi Arabia)
- EBITDA and EBIT margins stood at 4.7% and 0.9%, respectively

# Minsait 1Q26

## Backlog

€3,215m

+17.9%

## Order Intake

€1,107m

+8.8%

## Revenues

€752m

+1.3%

## EBITDA Margin

8.1%<sub>(€61m +3.9% YoY)</sub>

+0.2pp

## Operating Margin<sup>1</sup>

6.9%<sub>(€52m -0.9% YoY)</sub>

-0.1pp

## EBIT Margin

5.8%<sub>(€43m +3.6% YoY)</sub>

+0.2pp

## Book-to-Bill

1.47x

1.37x in 1Q25

## Backlog/Revs LTM

1.02x

0.91x in 1Q25

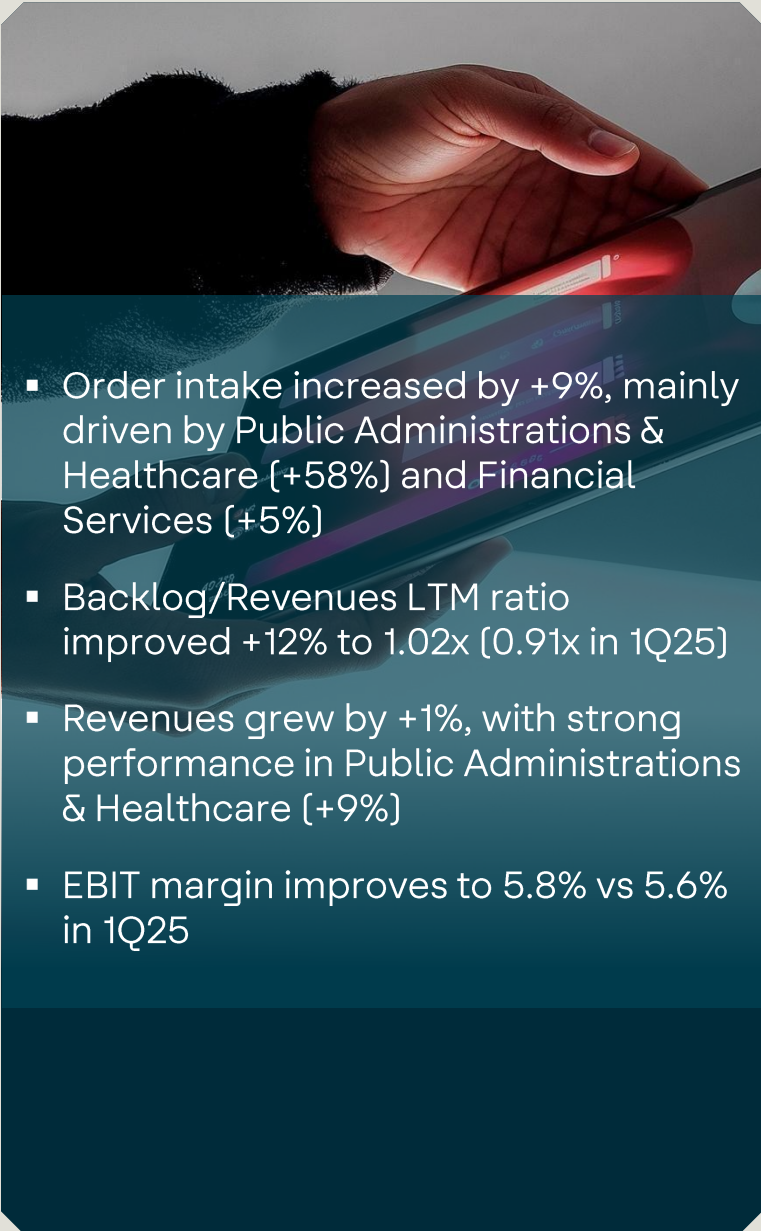
- 
- Order intake increased by +9%, mainly driven by Public Administrations & Healthcare [+58%] and Financial Services [+5%]
  - Backlog/Revenues LTM ratio improved +12% to 1.02x (0.91x in 1Q25)
  - Revenues grew by +1%, with strong performance in Public Administrations & Healthcare [+9%]
  - EBIT margin improves to 5.8% vs 5.6% in 1Q25

1. EBIT before Other Operating Income & Expenses, including staff reorganization, impairments, capital gains, integration and acquisition costs, fines, amortization of intangible assets (PPA from acquisitions) and equity-based compensation;

# 2026 Priorities

- Strategic Plan Leading the Future Scale-Up presentation before October 31<sup>st</sup>
- Continue Industrial Plan implementation to deliver backlog programmes
- Boost internationalization (organic and inorganic) to profit from geopolitical context
- Continue Indra Group's evolution towards culture of excellence



# Indra Group reaffirms its 2026 financial guidance

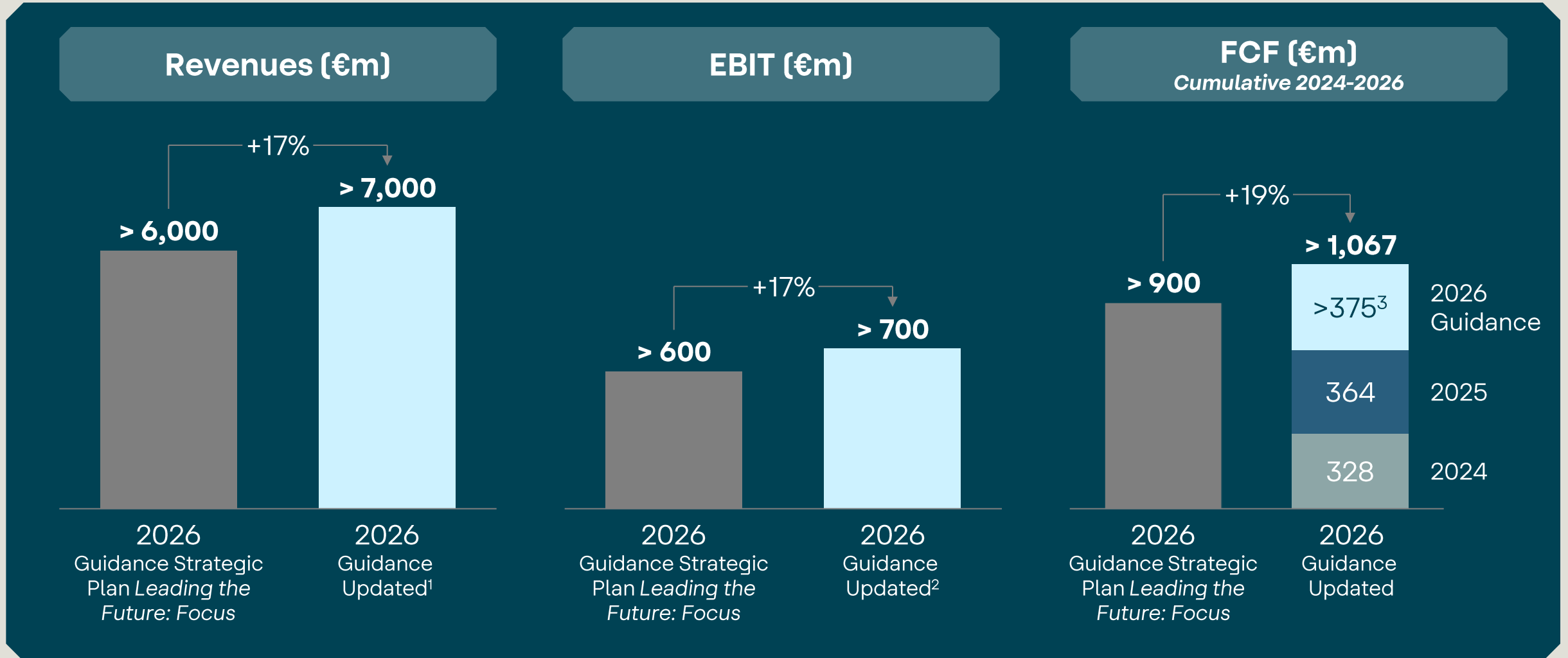

# 1Q26 FCF Generation

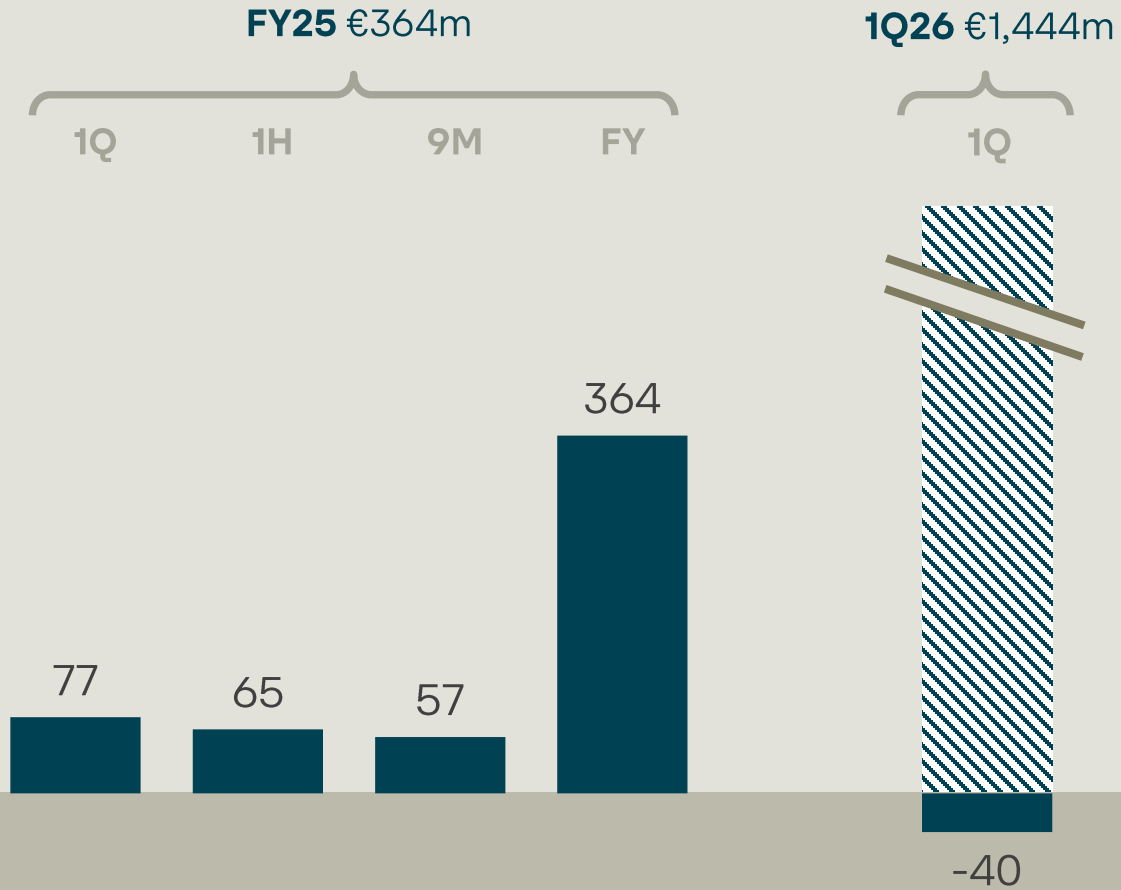

Quarterly reported cumulative FCF (€m)

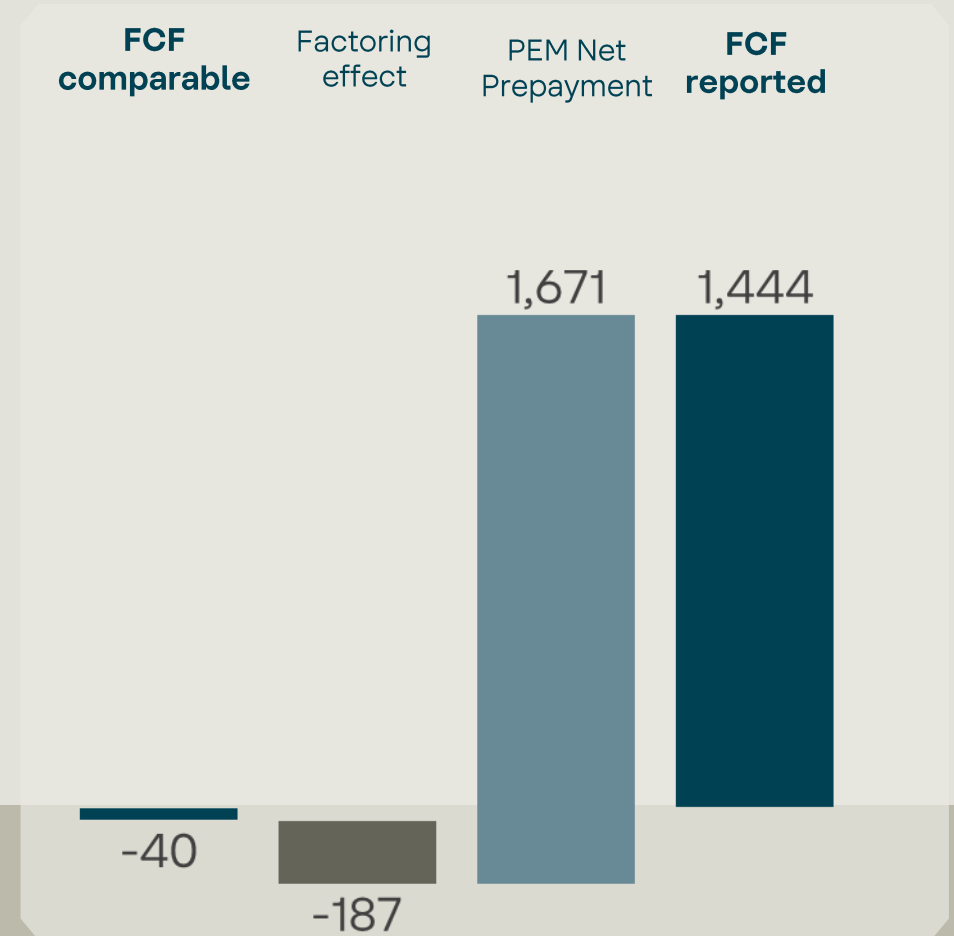

Comparable FCF (€m)

# Net Working Capital Evolution

## Net Working Capital ST+LT (DoS)



# 1Q26 Net Debt bridge

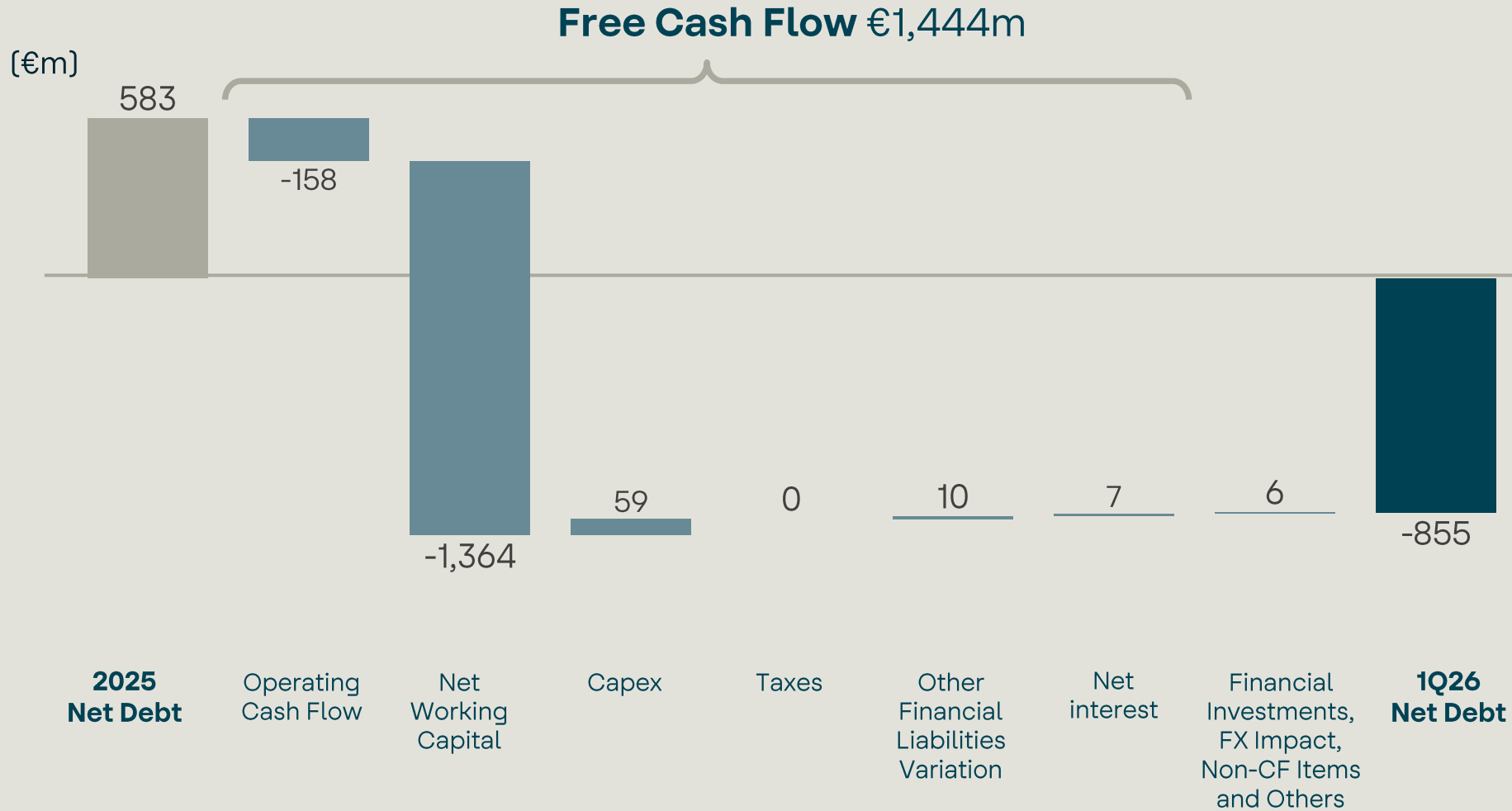

# Net Debt/EBITDA Evolution

## Net Debt (€m)

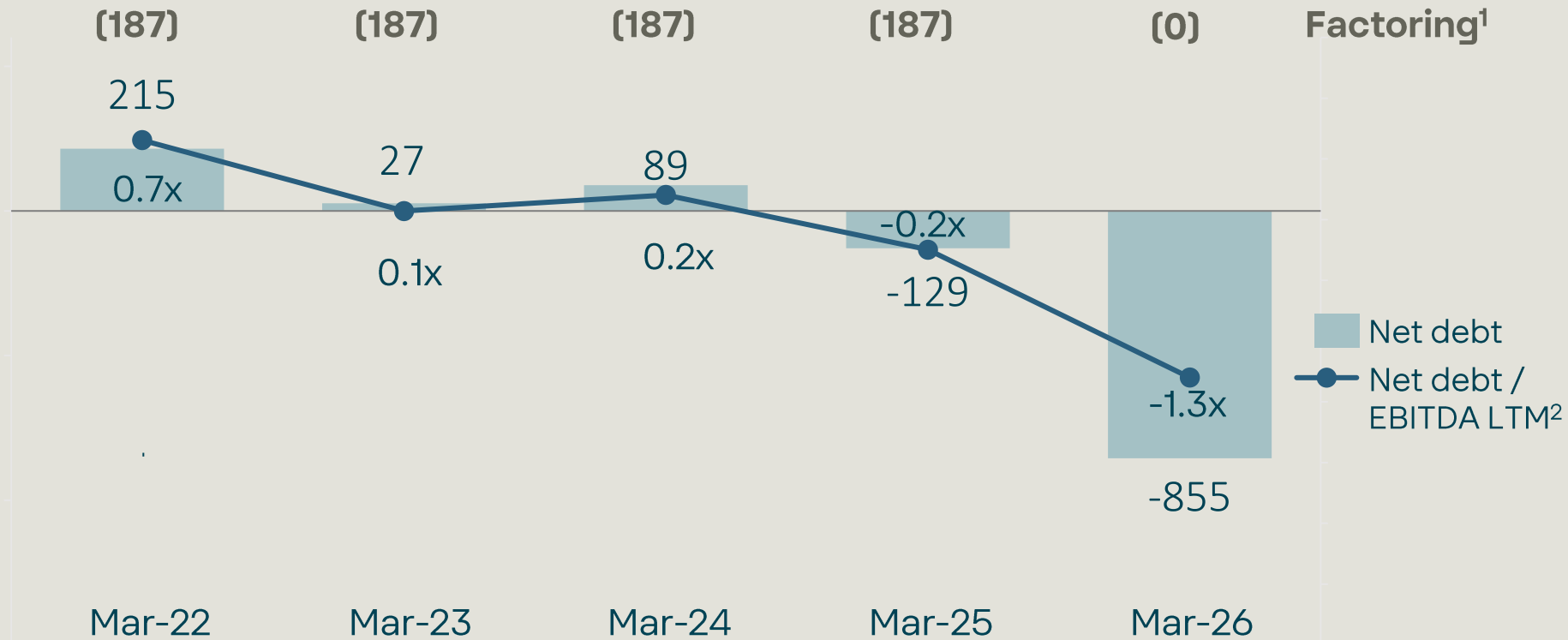

1. Non-recourse factoring; 2. EBITDA LTM excluding IFRS 16, extraordinary items related to employee restructuring plans

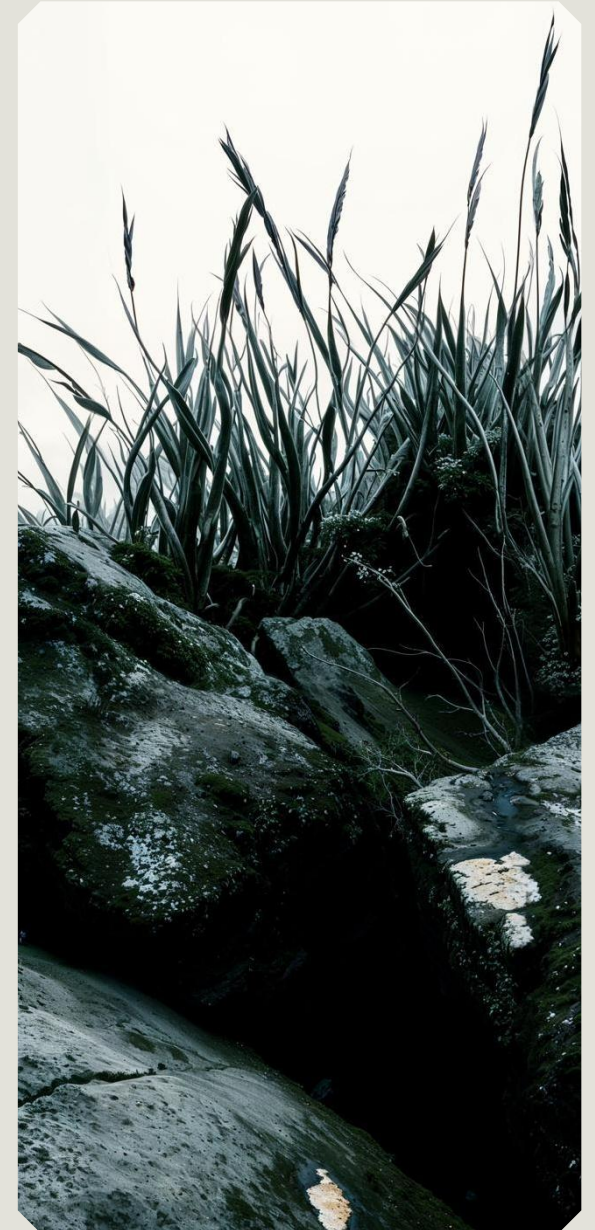

# Diversified Debt Structure

## Gross and Net Debt Structure

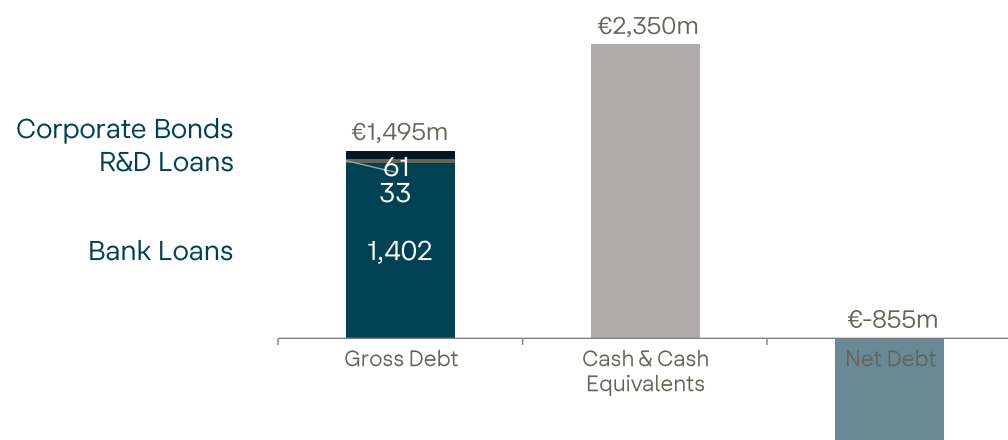

Other available credit facilities: €1,015<sup>1</sup> m

	1Q26	FY25
Average life (years)	3.9	3.1

## Gross Debt Maturity Profile

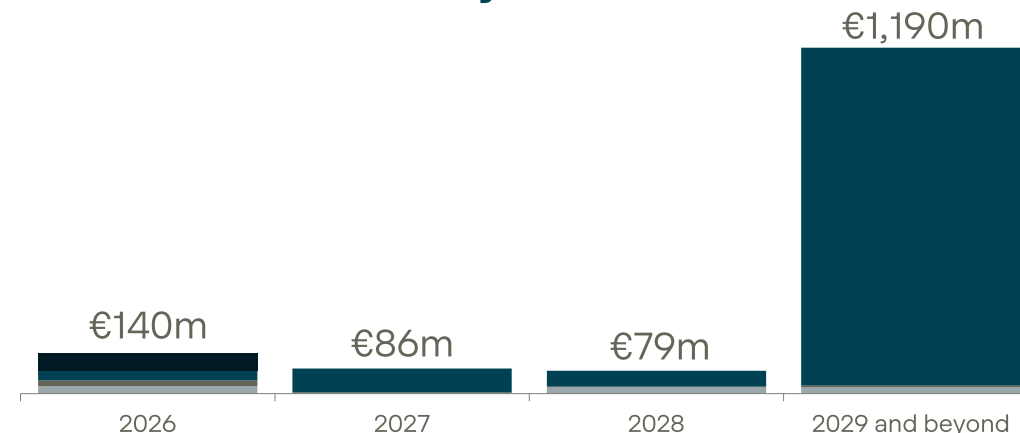

	(€m)	1Q26	% total	FY25	% total
L/T Debt		1,329	89%	1,197	76%
S/T Debt		166	11%	386	24%
Gross Debt		1,495	100%	1,583	100%
Cost of Gross Debt		2.9%		3.1%	
Cash & Others before transfer to held for sale		2,330	n.m.	976	n.m.
Cash & Others after transfer to held for sale		2,350		1,000	
<b>Net Debt</b>		<b>-855</b>	<b>n.m.</b>	<b>583</b>	<b>n.m.</b>

1. Includes €385m EIB Facility with defined use of proceeds

\*The gross debt of Hispasat amounted €144m and cash from Hispasat & Hisdesat amounted €187m

